

# TCRP

## REPORT 153

TRANSIT  
COOPERATIVE  
RESEARCH  
PROGRAM

### Guidelines for Providing Access to Public Transportation Stations

Sponsored by  
the Federal  
Transit Administration



TRANSPORTATION RESEARCH BOARD  
OF THE NATIONAL ACADEMIES

## TCRP OVERSIGHT AND PROJECT SELECTION COMMITTEE\*

### CHAIR

**Keith Parker**  
VIA Metropolitan Transit

### MEMBERS

**John Bartosiewicz**  
McDonald Transit Associates  
**Michael Blaylock**  
Jacksonville Transportation Authority  
**Raul Bravo**  
Raul V. Bravo & Associates  
**Terry Garcia Crews**  
Metro Cincinnati  
**Carolyn Flowers**  
Charlotte Area Transit System  
**Angela Iannuzziello**  
Genivar Consultants  
**John English**  
Utah Transit Authority  
**Paul Jablonski**  
San Diego Metropolitan Transit System  
**Sherry Little**  
Spartan Solutions LLC  
**Jonathan H. McDonald**  
HNTB Corporation  
**Gary W. McNeil**  
GO Transit  
**Bradford Miller**  
Pinellas Suncoast Transit Authority  
**Frank Otero**  
PACO Technologies  
**Peter Rogoff**  
FTA  
**Jeffrey Rosenberg**  
Amalgamated Transit Union  
**Richard Sarles**  
Washington Metropolitan Area Transit Authority  
**Michael Scanlon**  
San Mateo County Transit District  
**James Stem**  
United Transportation Union  
**Gary Thomas**  
Dallas Area Rapid Transit  
**Frank Tobey**  
First Transit  
**Matthew O. Tucker**  
North County Transit District  
**Phillip Washington**  
Denver Regional Transit District  
**Alice Wiggins-Tolbert**  
Parsons Brinckerhoff

### EX OFFICIO MEMBERS

**Michael P. Melaniphy**  
APTA  
**Robert E. Skinner, Jr.**  
TRB  
**John C. Horsley**  
AASHTO  
**Victor Mendez**  
FHWA

### TDC EXECUTIVE DIRECTOR

**Louis Sanders**  
APTA

### SECRETARY

**Christopher W. Jenks**  
TRB

## TRANSPORTATION RESEARCH BOARD 2012 EXECUTIVE COMMITTEE\*

### OFFICERS

CHAIR: **Sandra Rosenbloom**, Professor of Planning, University of Arizona, Tucson  
VICE CHAIR: **Deborah H. Butler**, Executive Vice President, Planning, and CIO, Norfolk Southern Corporation, Norfolk, VA  
EXECUTIVE DIRECTOR: **Robert E. Skinner, Jr.**, Transportation Research Board

### MEMBERS

**J. Barry Barker**, Executive Director, Transit Authority of River City, Louisville, KY  
**William A.V. Clark**, Professor of Geography and Professor of Statistics, Department of Geography, University of California, Los Angeles  
**Eugene A. Conti, Jr.**, Secretary of Transportation, North Carolina DOT, Raleigh  
**James M. Crites**, Executive Vice President of Operations, Dallas-Fort Worth International Airport, TX  
**Paula J. C. Hammond**, Secretary, Washington State DOT, Olympia  
**Michael W. Hancock**, Secretary, Kentucky Transportation Cabinet, Frankfort  
**Chris T. Hendrickson**, Duquesne Light Professor of Engineering, Carnegie-Mellon University, Pittsburgh, PA  
**Adib K. Kanafani**, Professor of the Graduate School, University of California, Berkeley  
**Gary P. LaGrange**, President and CEO, Port of New Orleans, LA  
**Michael P. Lewis**, Director, Rhode Island DOT, Providence  
**Susan Martinovich**, Director, Nevada DOT, Carson City  
**Joan McDonald**, Commissioner, New York State DOT, Albany  
**Michael R. Morris**, Director of Transportation, North Central Texas Council of Governments, Arlington  
**Neil J. Pedersen**, Consultant, Silver Spring, MD  
**Tracy L. Rosser**, Vice President, Regional General Manager, Wal-Mart Stores, Inc., Mandeville, LA  
**Henry G. (Gerry) Schwartz, Jr.**, Chairman (retired), Jacobs/Sverdrup Civil, Inc., St. Louis, MO  
**Beverly A. Scott**, General Manager and CEO, Metropolitan Atlanta Rapid Transit Authority, Atlanta, GA  
**David Seltzer**, Principal, Mercator Advisors LLC, Philadelphia, PA  
**Kumares C. Sinha**, Olson Distinguished Professor of Civil Engineering, Purdue University, West Lafayette, IN  
**Thomas K. Sorel**, Commissioner, Minnesota DOT, St. Paul  
**Daniel Sperling**, Professor of Civil Engineering and Environmental Science and Policy; Director, Institute of Transportation Studies; and Acting Director, Energy Efficiency Center, University of California, Davis  
**Kirk T. Steudle**, Director, Michigan DOT, Lansing  
**Douglas W. Stotlar**, President and CEO, Con-Way, Inc., Ann Arbor, MI  
**C. Michael Walton**, Ernest H. Cockrell Centennial Chair in Engineering, University of Texas, Austin

### EX OFFICIO MEMBERS

**Rebecca M. Brewster**, President and COO, American Transportation Research Institute, Smyrna, GA  
**Anne S. Ferro**, Administrator, Federal Motor Carrier Safety Administration, U.S.DOT  
**LeRoy Gishi**, Chief, Division of Transportation, Bureau of Indian Affairs, U.S. Department of the Interior, Washington, DC  
**John T. Gray II**, Senior Vice President, Policy and Economics, Association of American Railroads, Washington, DC  
**John C. Horsley**, Executive Director, American Association of State Highway and Transportation Officials, Washington, DC  
**Michael P. Huerta**, Acting Administrator, Federal Aviation Administration, U.S.DOT  
**David T. Matsuda**, Administrator, Maritime Administration, U.S.DOT  
**Michael P. Melaniphy**, President and CEO, American Public Transportation Association, Washington, DC  
**Victor M. Mendez**, Administrator, Federal Highway Administration, U.S.DOT  
**Tara O'Toole**, Under Secretary for Science and Technology, U.S. Department of Homeland Security, Washington, DC  
**Robert J. Papp** (Adm., U.S. Coast Guard), Commandant, U.S. Coast Guard, U.S. Department of Homeland Security, Washington, DC  
**Cynthia L. Quarterman**, Administrator, Pipeline and Hazardous Materials Safety Administration, U.S.DOT  
**Peter M. Rogoff**, Administrator, Federal Transit Administration, U.S.DOT  
**David L. Strickland**, Administrator, National Highway Traffic Safety Administration, U.S.DOT  
**Joseph C. Szabo**, Administrator, Federal Railroad Administration, U.S.DOT  
**Polly Trottenberg**, Assistant Secretary for Transportation Policy, U.S.DOT  
**Robert L. Van Antwerp** (Lt. Gen., U.S. Army), Chief of Engineers and Commanding General, U.S. Army Corps of Engineers, Washington, DC  
**Barry R. Wallerstein**, Executive Officer, South Coast Air Quality Management District, Diamond Bar, CA  
**Gregory D. Winfree**, Acting Administrator, Research and Innovative Technology Administration, U.S.DOT

\*Membership as of December 2011.

\*Membership as of February 2012.

---

---

**TCRP REPORT 153**

---

---

**Guidelines for Providing Access to  
Public Transportation Stations**

**Kathryn Coffel  
Jamie Parks  
Conor Semler  
Paul Ryus**

**KITTELSON & ASSOCIATES, INC.**  
Portland, OR

**David Sampson**  
**AECOM**  
Southport, CT

**Carol Kachadoorian**  
**TOOLE DESIGN GROUP, LLC**  
Washington, DC

**Herbert S. Levinson**  
Wallingford, CT

**Joseph L. Schofer**  
Wilmette, IL

*Subscriber Categories*

Public Transportation • Planning and Forecasting

---

Research sponsored by the Federal Transit Administration in cooperation with the Transit Development Corporation

---

**TRANSPORTATION RESEARCH BOARD**

WASHINGTON, D.C.  
2012  
[www.TRB.org](http://www.TRB.org)

## TRANSIT COOPERATIVE RESEARCH PROGRAM

The nation's growth and the need to meet mobility, environmental, and energy objectives place demands on public transit systems. Current systems, some of which are old and in need of upgrading, must expand service area, increase service frequency, and improve efficiency to serve these demands. Research is necessary to solve operating problems, to adapt appropriate new technologies from other industries, and to introduce innovations into the transit industry. The Transit Cooperative Research Program (TCRP) serves as one of the principal means by which the transit industry can develop innovative near-term solutions to meet demands placed on it.

The need for TCRP was originally identified in *TRB Special Report 213—Research for Public Transit: New Directions*, published in 1987 and based on a study sponsored by the Urban Mass Transportation Administration—now the Federal Transit Administration (FTA). A report by the American Public Transportation Association (APTA), *Transportation 2000*, also recognized the need for local, problem-solving research. TCRP, modeled after the longstanding and successful National Cooperative Highway Research Program, undertakes research and other technical activities in response to the needs of transit service providers. The scope of TCRP includes a variety of transit research fields including planning, service configuration, equipment, facilities, operations, human resources, maintenance, policy, and administrative practices.

TCRP was established under FTA sponsorship in July 1992. Proposed by the U.S. Department of Transportation, TCRP was authorized as part of the Intermodal Surface Transportation Efficiency Act of 1991 (ISTEA). On May 13, 1992, a memorandum agreement outlining TCRP operating procedures was executed by the three cooperating organizations: FTA, the National Academies, acting through the Transportation Research Board (TRB); and the Transit Development Corporation, Inc. (TDC), a nonprofit educational and research organization established by APTA. TDC is responsible for forming the independent governing board, designated as the TCRP Oversight and Project Selection (TOPS) Committee.

Research problem statements for TCRP are solicited periodically but may be submitted to TRB by anyone at any time. It is the responsibility of the TOPS Committee to formulate the research program by identifying the highest priority projects. As part of the evaluation, the TOPS Committee defines funding levels and expected products.

Once selected, each project is assigned to an expert panel, appointed by the Transportation Research Board. The panels prepare project statements (requests for proposals), select contractors, and provide technical guidance and counsel throughout the life of the project. The process for developing research problem statements and selecting research agencies has been used by TRB in managing cooperative research programs since 1962. As in other TRB activities, TCRP project panels serve voluntarily without compensation.

Because research cannot have the desired impact if products fail to reach the intended audience, special emphasis is placed on disseminating TCRP results to the intended end users of the research: transit agencies, service providers, and suppliers. TRB provides a series of research reports, syntheses of transit practice, and other supporting material developed by TCRP research. APTA will arrange for workshops, training aids, field visits, and other activities to ensure that results are implemented by urban and rural transit industry practitioners.

The TCRP provides a forum where transit agencies can cooperatively address common operational problems. The TCRP results support and complement other ongoing transit research and training programs.

## TCRP REPORT 153

Project B-38

ISSN 1073-4872

ISBN 978-0-309-21396-7

Library of Congress Control Number 2012933415

© 2012 National Academy of Sciences. All rights reserved.

### COPYRIGHT INFORMATION

Authors herein are responsible for the authenticity of their materials and for obtaining written permissions from publishers or persons who own the copyright to any previously published or copyrighted material used herein.

Cooperative Research Programs (CRP) grants permission to reproduce material in this publication for classroom and not-for-profit purposes. Permission is given with the understanding that none of the material will be used to imply TRB, AASHTO, FAA, FHWA, FMCSA, FTA, or Transit Development Corporation endorsement of a particular product, method, or practice. It is expected that those reproducing the material in this document for educational and not-for-profit uses will give appropriate acknowledgment of the source of any reprinted or reproduced material. For other uses of the material, request permission from CRP.

### NOTICE

The project that is the subject of this report was a part of the Transit Cooperative Research Program, conducted by the Transportation Research Board with the approval of the Governing Board of the National Research Council.

The members of the technical panel selected to monitor this project and to review this report were chosen for their special competencies and with regard for appropriate balance. The report was reviewed by the technical panel and accepted for publication according to procedures established and overseen by the Transportation Research Board and approved by the Governing Board of the National Research Council.

The opinions and conclusions expressed or implied in this report are those of the researchers who performed the research and are not necessarily those of the Transportation Research Board, the National Research Council, or the program sponsors.

The Transportation Research Board of the National Academies, the National Research Council, and the sponsors of the Transit Cooperative Research Program do not endorse products or manufacturers. Trade or manufacturers' names appear herein solely because they are considered essential to the object of the report.

*Published reports of the*

### TRANSIT COOPERATIVE RESEARCH PROGRAM

*are available from:*

Transportation Research Board  
Business Office  
500 Fifth Street, NW  
Washington, DC 20001

*and can be ordered through the Internet at*

<http://www.national-academies.org/trb/bookstore>

Printed in the United States of America

# THE NATIONAL ACADEMIES

*Advisers to the Nation on Science, Engineering, and Medicine*

The **National Academy of Sciences** is a private, nonprofit, self-perpetuating society of distinguished scholars engaged in scientific and engineering research, dedicated to the furtherance of science and technology and to their use for the general welfare. On the authority of the charter granted to it by the Congress in 1863, the Academy has a mandate that requires it to advise the federal government on scientific and technical matters. Dr. Ralph J. Cicerone is president of the National Academy of Sciences.

The **National Academy of Engineering** was established in 1964, under the charter of the National Academy of Sciences, as a parallel organization of outstanding engineers. It is autonomous in its administration and in the selection of its members, sharing with the National Academy of Sciences the responsibility for advising the federal government. The National Academy of Engineering also sponsors engineering programs aimed at meeting national needs, encourages education and research, and recognizes the superior achievements of engineers. Dr. Charles M. Vest is president of the National Academy of Engineering.

The **Institute of Medicine** was established in 1970 by the National Academy of Sciences to secure the services of eminent members of appropriate professions in the examination of policy matters pertaining to the health of the public. The Institute acts under the responsibility given to the National Academy of Sciences by its congressional charter to be an adviser to the federal government and, on its own initiative, to identify issues of medical care, research, and education. Dr. Harvey V. Fineberg is president of the Institute of Medicine.

The **National Research Council** was organized by the National Academy of Sciences in 1916 to associate the broad community of science and technology with the Academy's purposes of furthering knowledge and advising the federal government. Functioning in accordance with general policies determined by the Academy, the Council has become the principal operating agency of both the National Academy of Sciences and the National Academy of Engineering in providing services to the government, the public, and the scientific and engineering communities. The Council is administered jointly by both Academies and the Institute of Medicine. Dr. Ralph J. Cicerone and Dr. Charles M. Vest are chair and vice chair, respectively, of the National Research Council.

The **Transportation Research Board** is one of six major divisions of the National Research Council. The mission of the Transportation Research Board is to provide leadership in transportation innovation and progress through research and information exchange, conducted within a setting that is objective, interdisciplinary, and multimodal. The Board's varied activities annually engage about 7,000 engineers, scientists, and other transportation researchers and practitioners from the public and private sectors and academia, all of whom contribute their expertise in the public interest. The program is supported by state transportation departments, federal agencies including the component administrations of the U.S. Department of Transportation, and other organizations and individuals interested in the development of transportation. **[www.TRB.org](http://www.TRB.org)**

**[www.national-academies.org](http://www.national-academies.org)**

# COOPERATIVE RESEARCH PROGRAMS

## **CRP STAFF FOR TCRP REPORT 153**

**Christopher W. Jenks**, *Director, Cooperative Research Programs*  
**Crawford F. Jencks**, *Deputy Director, Cooperative Research Programs*  
**Dianne S. Schwager**, *Senior Program Officer*  
**Jeffrey L. Oser**, *Senior Program Assistant*  
**Eileen P. Delaney**, *Director of Publications*  
**Margaret B. Hagood**, *Editor*

## **TCRP PROJECT B-38 PANEL**

### **Field of Service Configuration**

**Gary W. McNeil**, *GO Transit, Toronto, ON (Chair)*  
**Tunde Balvanyos**, *Parsons Brinckerhoff, San Diego, CA*  
**Jeffrey M. Dunning**, *Denver Regional Transportation District, Denver, CO*  
**Peter Fahrenwald**, *Regional Transportation Authority, Chicago, IL*  
**Susan Mary Harrington**, *California DOT, Sacramento, CA*  
**Meredith Highsmith**, *Texas Transportation Institute, Austin, TX*  
**David A. Lee**, *Connecticut Transit, Hartford, CT*  
**Peter C. Martin**, *Wilbur Smith Associates, San Francisco, CA*  
**Douglas Moore**, *Central Ohio Transit Authority, Columbus, OH*  
**Daniel O'Connell**, *Metropolitan Transportation Authority-Metro-North Railroad, New York City, NY*  
**Jennifer Rephlo**, *Science Applications International Corporation, McLean, VA*  
**Thobias M. Sando**, *University of North Florida, Jacksonville, FL*  
**Peggy Schwartz**, *Transportation Action Partnership Inc., North Bethesda, MD*  
**Sarah Stott**, *Arlington County (VA), Arlington, VA*  
**Jarrett W. Stoltzfus**, *FTA Liaison*  
**Charlene Wilder**, *FTA Liaison*  
**Allen Greenberg**, *US DOT Liaison*

## **AUTHOR ACKNOWLEDGMENTS**

The research reported herein was performed under TCRP Project B-38 by Kittelson & Associates, Inc. (prime contractor), assisted by AECOM, Toole Design Group, LLC; Herbert S. Levinson; and Dr. Joseph L. Schofer. Kathryn Coffel of Kittelson & Associates, Inc. was the principal investigator. Jamie Parks was instrumental throughout the project, leading much of the literature review, case study work, data collection, and final report writing. He provided the sections on pedestrian and bicycle guidelines. Jamie Parks and Conor Semler developed the Station Access Planning Tool. Adam Vest assisted on several of the detailed case studies. Paul Ryus provided project oversight and final review of the guidebook.

David Sampson of AECOM, supported by Christopher Henry and Guillermo Calves, assisted with the literature review, and conducted initial and detailed case studies. Carol Kachadoorian of Toole Design Group, LLC led the bicycle and pedestrian access literature review, initial case studies, and the detailed case study of the Washington Metropolitan Transit Authority. Herbert S. Levinson provided the automobile access literature review, assistance on the detailed case studies, and the parking access guidelines, and pulled together the initial work into the final guidebook. Dr. Joseph L. Schofer developed the station access planning process and provided assistance with the detailed case studies.

The project team thanks the numerous organizations and persons who participated in the project's outreach efforts, and particularly those who participated in the detailed case studies, and tested the Station Access Planning Tool.



# FOREWORD

By **Dianne S. Schwager**

Staff Officer

Transportation Research Board

*TCRP Report 153: Guidelines for Providing Access to Public Transportation Stations* provides a process and spreadsheet-based tool for effectively planning for access to high capacity transit stations, including commuter rail, heavy rail, light rail, bus rapid transit (BRT), and ferry. The report is accompanied by a CD that includes the station access planning spreadsheet tool that allows trade-off analyses among the various access modes (automobile, transit, bicycle, pedestrian, and transit-oriented development) for different station types. The potential effectiveness of transit-oriented development opportunities to increase transit ridership is also assessed. This report and accompanying materials are intended to aid the many groups involved in planning, developing, and improving access to high capacity transit stations, including public transportation and highway agencies, planners, developers, and affected citizens.

---

*TCRP Report 153* addresses planning and design for access to high capacity transit stations, including guidelines for arranging and integrating various station design elements. The report

- Provides a detailed eight-step planning process for effective station access planning;
- Provides elements of successful station access planning and specific lessons learned from research case studies to improve the effectiveness of the planning process;
- Sets forth a comprehensive station typology, provides information on station boarding and arrival volumes and access modes by station type, and provides guidance for establishing policy for station mode of access;
- Presents techniques for estimated travel demand in terms of station boardings by mode and introduces the station access planning tool;
- Discusses station arrangement and design, and provides broad objectives and considerations for improving station access;
- Presents guidelines for enhancing pedestrian access to, from, and within station areas;
- Offers guidance relating to bicycle access and parking;
- Contains guidance for improving the efficiency and effectiveness of feeder transit access;
- Covers park-and-ride locations and arrangements to stations; and
- Discusses transit-oriented development and its relation to station access and parking.

The appendices to *TCRP Report 153* provide detailed additional information and are available on the accompanying CD.

**Appendix A** summarizes the stakeholder interviews and literature review that formed a basis for the guidance provided in this report; the full literature review is available as



*TCRP Web-Only Document 44: Literature Review for Providing Access to Public Transportation Stations;*

**Appendix B** provides an overview of existing analysis tools related to transit station access;

**Appendix C** presents a spreadsheet-based station analysis tool for assessing various station access alternatives and instructions for use and provides detailed instructions on using the tool;

**Appendix D** includes a summary of existing data related to transit access collected as part of the research project, including access mode share characteristics for select stations throughout the United States; and

**Appendix E** contains the project's 11 case studies. The case studies illustrate the organizational elements for successful station access planning, and provide applications for elements of the eight-step planning process to specific stations at each of the eleven case study transit agencies.

The appendices and planning tool are available at the TRB website at <http://www.trb.org/Main/Blurbs/166516.aspx>.



# CONTENTS

<b>1</b>	<b>Chapter 1 Introduction</b>
1	Background
1	Key Issues
2	General Guidelines
3	Organization of the Guidelines
4	Future Research Needs
<b>5</b>	<b>Chapter 2 Station Access Planning Tools and Process</b>
5	Successful Station Access Planning
6	The Station Access Planning Process
<b>19</b>	<b>Chapter 3 Insights from Transit Agencies</b>
19	Elements of Successful Station Access Planning
25	Improving Station Access Planning
26	Insights from the Case Studies
<b>33</b>	<b>Chapter 4 Station Typology, Access Modes, and Access Policy Guidance</b>
33	General Considerations
33	Station Typologies
35	Examples of Station Arrival Modes
43	Access Policy Guidelines
<b>44</b>	<b>Chapter 5 Travel Demand Considerations</b>
44	Review of Practice
46	Station Access Model
48	Effects of Improved Station Access
51	Estimating Ridership for New and Infill Stations
<b>54</b>	<b>Chapter 6 General Station Access Guidelines</b>
54	Background
56	Station Access Objectives
56	Additional Considerations
57	Overview of Options
58	Sequence of Access Design Chapters
<b>59</b>	<b>Chapter 7 Pedestrian Access to Transit</b>
59	Context
60	Interagency Coordination
60	Factors Affecting Pedestrian Access
61	Design Principles
<b>66</b>	<b>Chapter 8 Bicycle Access to Transit</b>
67	Interagency Coordination

68	Factors Affecting Bicycle Access
69	Bicycle Access Improvements
<b>77</b>	<b>Chapter 9 Transit Access</b>
77	General Planning Guidelines
80	Access Objectives and Guidelines
85	Bus Characteristics
86	Bus Operating Practice and Terminal Design
89	Terminal Access and Arrangement
<b>92</b>	<b>Chapter 10 Automobile Access and Park-and-Ride</b>
92	Overview and Objectives
94	User and Usage Characteristics
98	Planning Guidelines
105	Traffic and Parking Management Guidelines
106	Facility Arrangement and Design
113	Operations and Maintenance
<b>115</b>	<b>Chapter 11 TOD and Station Access</b>
115	Issues and Opportunities
117	Development Types and Sizes
119	TOD—Where Does It Work?
120	General Guidelines
123	Comparisons of TOD and Park-and-Ride
128	Implications and Directions
<b>130</b>	<b>References</b>
<b>133</b>	<b>List of Agency Abbreviations</b>
<b>134</b>	<b>Appendices A Through E</b>

---

Note: Many of the photographs, figures, and tables in this report have been converted from color to grayscale for printing. The electronic version of the report (posted on the Web at [www.trb.org](http://www.trb.org)) retains the color versions.

# Introduction

This report presents guidelines for providing access to rapid transit stations, describes a station access planning process, and provides a high-level station access planning tool. The guidelines, process, and planning tool are based on a detailed review of available literature and transit agency practices, as well as case studies conducted during the course of the research. The materials are intended to aid the many groups involved in planning, developing and improving station access. These groups include public transportation and highway agencies, planners, developers, and affected citizens.

The guidelines and planning tool cover access to transit stations for high-capacity transit services, including commuter rail, heavy rail transit, light rail transit, and bus rapid transit. These services are considered as “rapid transit” in the discussion throughout the guide.

## Background

Access to rapid transit service in the early years of the twentieth century was mainly as pedestrians. Stations were closely spaced (one-quarter to one-half mile), enabling passengers to easily reach stations. Over the years, bus transit access—usually on intersecting streets—became common in older rapid transit systems. Several systems have free or low-cost transfers to the rapid transit lines. Transit-Oriented Development (TOD) emerged around many stations.

Extensive suburbanization in post–World War II America resulted in low-density development surrounding the central city. Rapid transit development—both along older rapid transit lines (i.e., “legacy” lines) and new lines—involved wider station spacing (one to two miles) and higher line-haul speeds. Station access became more complex and was increasingly dominated by automobile access and large park-and-ride facilities.

## Key Issues

Several issues underlie contemporary rapid transit station access planning:

- What is the best way or “process” for station planning and development?
- Which groups should be included in this planning process?
- What travel modes should be accommodated?
- How do development densities and land use patterns affect the use of various access modes?
- How can station ridership and access modes use be estimated?
- What are the likely effects of parking on station ridership?
- How can the sometimes-differing concerns of transit agencies and communities be addressed?
- How do access issues vary between mature and new stations?

- How should pedestrian, bicycle, transit, and auto access be integrated into the site plan for the station and its environs?
- What guidelines underlie the provisions of park-and-ride? When are garages preferable to surface parking?
- What provisions should be made for TOD and integrating station access with the surrounding neighborhoods?
- Under what circumstances are feeder bus services likely to provide a cost-effective means of providing station access?
- What are ways to maximize access at constrained stations?

## General Guidelines

Following are general guidelines on providing access to transit stations. These are described in greater detail in various chapters of this report.

- Providing access to rapid transit stations should be a cooperative effort by the transit, street transportation, and planning agencies, as well as the surrounding community. The transit agency should be proactive in this effort.
- Station access plans should result from comprehensive and cooperative planning processes that identify needs and opportunities and lead to effective and accepted results.
- Station access generally should be multi-modal.
- The predominant access travel modes depend upon type of land use, street spacing, and development density, among other factors (see Exhibit 1-1). Walking dominates station access in the city center and in contiguous high-density residential areas. Both walking and bus access are the main means of reaching stations within the central city. Suburban stations are typically serviced by autos, buses, and pedestrians.

Exhibit 1-1 provides only a summary of key factors related to access; many other factors also affect the mix of access modes at a given station (e.g., network connectivity). Chapter 4 provides detailed information on the different types of transit stations and the various factors that typically affect access.

- Improvements to station access should consider the planned build-out of the station area so as not to conflict with or inhibit future planning.

**Exhibit 1-1. Land use and development density.**

Location Type	Typical Distance from City Center (miles)	Typical Net Residential Density (people/sq. mi.)	Primary Arrival Modes <sup>1</sup>
Central Business District	0 – 2	NA	Pedestrian
Central City	2 – 10	8,000 – 20,000	Pedestrian Bus
Inner Suburbs	10 – 15	4,000 – 6,000	Park-and-Ride Bus
Outer Suburbs	15 – 25	2,500 – 4,000	Park-and-Ride
Exurbia	Over 25	Varies	Park-and-Ride

<sup>1</sup> Primary arrival modes indicate how the majority of riders access the station, although most stations will attract at least some from all access modes.

- Since there are variations in land use and density, more specific guidance is necessary. Accordingly, a 12-station typology based on eight factors is provided to guide station access decisions.
- TOD in the station environs may be fostered when warranted by market considerations, but should be balanced with the need to provide adequate parking near stations to sustain ridership.
- Development adjacent to stations should feature transit-oriented design characteristics (e.g., pedestrian-friendly, direct transit access from local land uses) to maximize ridership potential.
- Pedestrian circulation should form the foundation of the station access plan. Transit passengers walk between home and bus stops, between bus stops and station entrances, and between parking facilities and station entrances. They then walk through the station to the rail or bus platforms. Each step of this trip should be convenient and safe.
- Specific station, site, roadway, and parking plans should conform to established standards of transit and highway agencies. However, flexibility in design requirements may allow for more efficient use of space in constrained situations (e.g., smaller width parking spaces to increase parking capacity at high demand stations).

## Organization of the Guidelines

This guide contains two basic sections. Part I covers planning, while Part II covers design.

### Part I, Rapid Transit Station Planning, has four chapters:

Chapter 2 provides a detailed eight-step planning process for station planning.

Chapter 3 provides specific lessons learned from research case studies to improve the effectiveness of the planning process.

Chapter 4 sets forth a station typology, provides information on station boarding and arrival volumes and access modes, and provides guidance for establishing policy for station mode of access.

Chapter 5 presents techniques for estimated travel demand in terms of station boards by mode and introduces the station access planning tool.

### Part II, Rapid Transit Station Access Arrangement and Design, provides guidelines for arranging and integrating various station design elements:

Chapter 6 overviews station arrangement and design, and provides general guidelines for improving station access.

Chapter 7 presents guidelines for enhancing pedestrian access to, from, and within station areas.

Chapter 8 offers guidance relating to bicycle access.

Chapter 9 contains guidance for improving feeder transit access.

Chapter 10 covers park-and-ride locations and arrangements to stations.

Chapter 11 discusses TOD and its relation to station access and parking.

## Appendices

The appendices provide detailed additional information:

Appendix A summarizes the stakeholder surveys and literature review that formed a basis for the guidance provided in this report;

Appendix B provides an overview of existing analysis tools related to transit station access; Appendix C, which is available electronically as an attachment to the report, presents a spreadsheet-based station analysis tool for assessing various station access alternatives and instructions for use. Appendix C offers detailed instructions on using the tool, which is available on a CD accompanying the report and online at [www.trb.org/Main/Blurbs/166516.aspx](http://www.trb.org/Main/Blurbs/166516.aspx). Appendix D includes a summary of existing data related to transit access collected as part of the research project, including access mode share characteristics for example stations throughout the United States; and Appendix E contains detailed descriptions of the project's case studies.

## Future Research Needs

The case studies clearly pointed to the lack of industry tools available for station mode of access planning. This research developed a station access planning tool (Appendix C) that provides the first industry tool designed specifically to evaluate the trade-offs between transit station access modes. The following two areas have been identified as the most critical for additional research:

1. **Predictive models** are important to answer critical “if/then” questions in support of station access planning (e.g., to predict ridership for an access mode or parking response to pricing changes). Several transportation agencies use proprietary models, usually developed by consultants. Traditional models used for regional transportation planning may not be sufficiently sensitive or detailed enough to evaluate station access mode options. This is a critical gap in available tools, particularly given the important role that station access services play in the success of major capital investment in rapid transit systems. Development of a state-of-the-art package of station access planning models could be a good research project.
2. **Comprehensive evaluation tools** are used to predict outcomes of various access-related actions. Few transit agencies have objective tools to estimate parking demand, the effect of TOD on ridership, and cost-effectiveness of feeder buses. The evaluation tool developed through this project is a reasonable starting point, but it can be refined and enhanced as agencies begin to apply it to real-world challenges. Developing such tools could be accomplished through a TCRP research project. Note that the accuracy of such tools in practice will likely rely on good input data from individual transit agencies.

# Station Access Planning Tools and Process

Station access planning is integral to the overall station development effort. Planning is essential for improving existing facilities and for designing new facilities. A major objective of the station access planning process is to achieve consensus from the various groups involved in the station planning effort. Consensus is a laudable goal in any planning process, but is particularly important for station access planning, as implementing many improvements requires multiple actors (e.g., successful joint development requires support from both the transit agency and local jurisdiction).

A second objective of the planning process is to encourage a multi-modal approach to station access planning and decision making. The following process is intended to aid agency planners in identifying multi-modal access priorities and weighing benefits and trade-offs.

This chapter contains best practices for station access planning, including the following primary elements:

- Principles of successful station access planning;
- A suggested eight-step planning process, with detailed information on the key characteristics of each step; and
- Suggested improvements to transit access planning based on the case studies conducted as part of this research.

The guidance is based on case study lessons learned from experiences of a number of agencies operating various forms of rapid transit. Chapter 3 summarizes the specific findings of each case study.

## Successful Station Access Planning

Successful rapid transit station access planning can be defined in terms of outcomes and process. Outcomes are the on-the-ground results of the access planning process: the services offered and their quality; community compatibility and integration; spillover effects; and, most importantly, access utilization. A little-used access service can hardly be considered a success. For station access planning to produce good outcomes, the rapid transit service itself should: (1) offer competitive service to major attractors; (2) have sufficient capacity to take on additional passengers; and (3) serve a sufficient existing or potential travel market—population and/or employment—within the station’s commuter-shed to make investments in improved access worthwhile.

Different settings usually require different station access solutions. Rapid transit services and stations on older systems that have stations in denser communities, such as MBTA (Boston) and Metro-North (New York) often have little or no capacity for increased commuter parking in built-up areas. Some municipalities within these older station areas actively discourage or



preclude station parking expansion. Access solutions may come in the form of increased bus service and pedestrian access to stations.

Newer rapid transit systems with more recently-built stations in lower-density and faster-growing, auto-dependent settings, such as RTD (Denver) and MARTA (Atlanta), require large amounts of parking to serve park-and-ride customers traveling longer distances to stations. These newer stations usually offer connecting bus services, but the availability of bus services generally dwindles as the distance from the central business district (CBD) increases and as development densities decline. This is also true for system extensions in Boston (MBTA) and Washington, D.C. (WMATA).

What constitutes successful utilization depends on context. In a low-density area, lightly used walk access is not likely to be viewed as a failure. On the other hand, poorly used transit and/or park-and-ride access at an end-of-line rapid transit station might be considered a failure.

Successful station access also requires seamless integration with the community, connectivity to adjacent residential and commercial areas, and absence of access-related spillover effects (e.g., congestion, neighborhood parking impacts, noise, crashes). Community satisfaction with station access services and facilities is an important measure of this relationship. A close collaboration with local governments is essential in defining success. The station planning process should help create this environment.

A vision of station build-out should be developed early, defining long range TOD goals and parking policies. To the extent feasible or appropriate for a given situation, this could also include interagency memoranda of understanding to establish agreement on key issues.

## **The Station Access Planning Process**

Good station access is essential for the success of rapid transit service, but can only be successful if the service has a strong market draw and offers competitive, quality service between significant trip generators.

Current and potential riders expect and demand seamless door-to-door transit services. Unless a rider's origin and destination is at the entrance to the rapid transit service (this might be the case for TOD), some kind of mobility is required for the first and last mile of the trip. Accessibility, in the case of TOD, or mobility, in the case of more distant access, are concerns and therefore the responsibility of the agency.

This responsibility is usually shared with local governments, feeder transit carriers, and private landowners and developers. These entities may control station access services, the land that is or could be used for station access, and the development and traffic management policies that may constrain or support station access improvement programs.

Two characteristics of the station access planning process are important contributors to success. First and most obvious, an effective process is necessary (but not sufficient) for producing good outcomes. Second, the process should bring satisfaction to participants in the process—not only to the professionals within the rapid transit agency, but more importantly, to the collaborators from local host communities, regional and state agencies, and affected private entities.

The planning process can be considered successful even if it does not produce a successful outcome. In this case, it may have value as a means of moving forward to other station access planning tasks; however, outcome success is ultimately the most important.

Exhibit 2-1 illustrates the relationship among the station access planning process, the context, and the access outcomes. This context will vary—sometimes substantially—among stations, communities, and regions.

**Exhibit 2-1. Relationship among the station access planning process activities.**

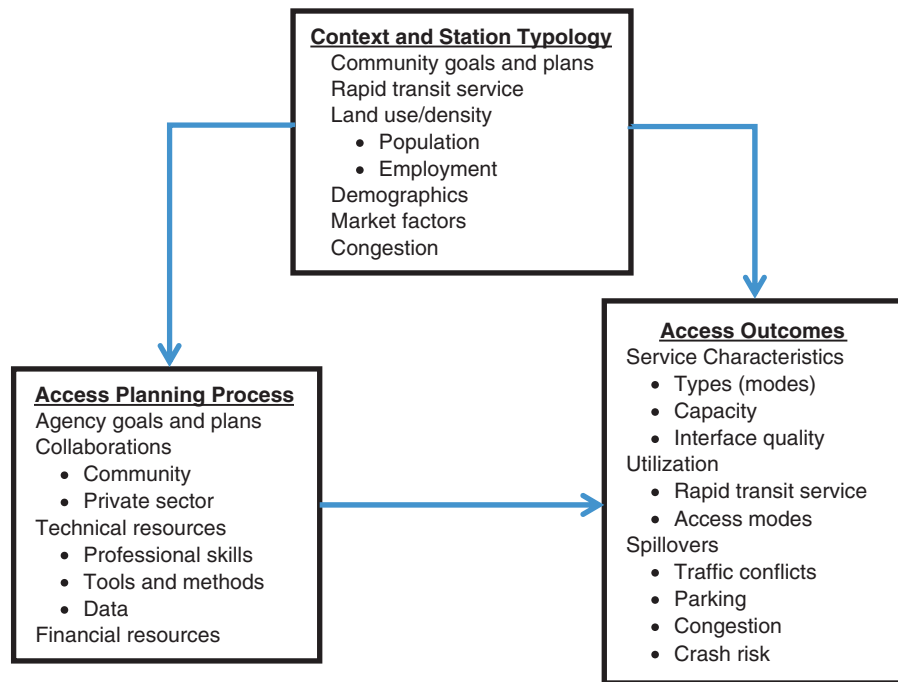

Exhibit 2-2 presents an idealized eight-step planning process based on the unique components of planning for access to transit. This process provides a general outline of the planning process, from identifying problems and engaging stakeholders at the outset to ultimately developing and implementing a preferred option. The process described here is not intended to be prescriptive, or to add unnecessary complexity to access planning.

Rather, it reflects an ideal, against which planning practices for transit station access can be measured to identify deficiencies and specific areas where improvements are desired, and is only one of many successful methods for conducting access planning. In practice, the steps may not occur in the order presented here and one or more steps may be skipped depending on the particular application. For instance, addressing the need for additional bicycle racks at a particular station may not require a detailed process, whereas introducing a feeder bus system may.

Exhibit 2-3 gives examples of best practices for each of the steps that are specific to transit station access planning. Not all best practices will apply to any given transit agency; some will already have been implemented and others will not be applicable to their specific situation. Achieving some improvements, such as developing new travel demand models, requires interagency collaboration and may take several years; others may be implemented almost immediately. The remainder of this chapter describes the access planning process and potential improvements in the context of station access planning.

## Step 1: Identify the Need

Station planning access initiatives generally fall into two categories:

1. Initiatives associated with existing and well-established stations, and often addressing problems of a long-standing nature. These needs are likely to be easily identifiable, but simple solutions may not be readily available (e.g., no space available to expand parking). Rapid transit station

**Exhibit 2-2. Eight-step station access planning flowchart.**

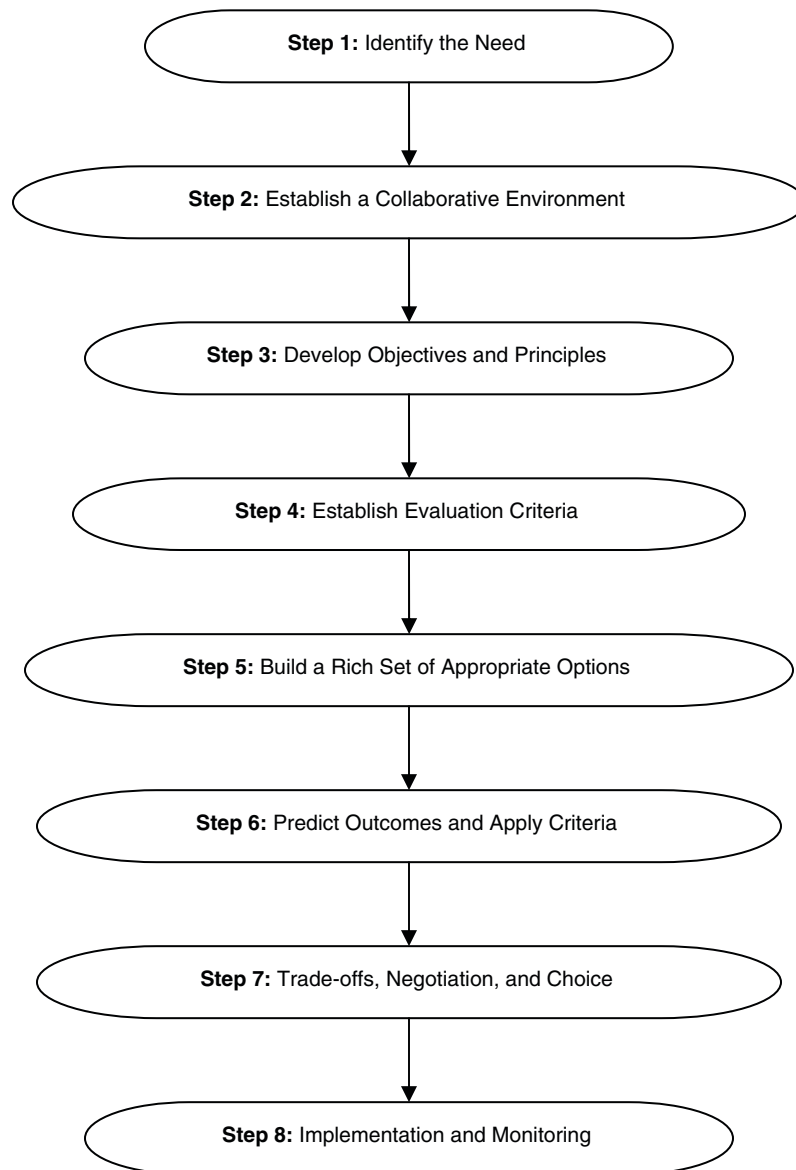

access planning for existing stations is often done on a station-by-station basis, and was often identified in the stakeholder interviews as “ad hoc,” “context sensitive,” or local in nature, and not related to larger concerns or part of an overriding set of agency goals and objectives.

2. Initiatives associated with long-term planning, new stations, new lines, or a combination of these. In these cases, station access planning is more likely to fall into a well-established and comprehensive planning strategy, and is often integrated into NEPA and New Starts analysis. The objectives for these planning processes are related to regional goals, and intertwined with regional objectives such as congestion mitigation, environmental greening, and TOD. These objectives are incorporated into the design and operating plans for the new lines and stations. Such efforts are more comprehensive than developing improvements for existing stations and are often contained in agency guidebooks.

Concerns with access to transit stations often follow patterns that can be addressed in a systematic fashion through an overall planning process. This helps organize activities and provides

**Exhibit 2-3. Summary of station access planning process.**

<b>Step</b>	<b>Examples of Best Practices</b>
1. Identify the need	Organize agency thinking/planning upfront Fully understand issues from multiple perspectives Recognize external (non-transit agency) problems
2. Establish a collaborative environment	Identify and include all stakeholders Acknowledge inter-relatedness of various stakeholder groups Establish shared goals for transportation, environment, and economic development Understand the traveler's perspective
3. Develop objectives and principles	Address concerns of multiple stakeholders Recognize the commonalities between different stations Develop a standard set of access goals and objectives that can be applied throughout system Identify opportunities and constraints
4. Establish evaluation criteria	Develop criteria related to a range of objectives, including ridership, costs, and local impacts Limit evaluation criteria to a manageable number (typically fewer than 10) Establish data collection program to support evaluation criteria
5. Build a rich set of appropriate options	Address existing and future needs Consider station access and ridership in route alignments and station designations Integrate community design into station development Coordinate station access design with land development Consider a wide range of improvements
6. Predict outcomes and apply criteria	Improve sensitivity of travel demand models to transit access improvements Use quantitative tools to assess TOD and parking replacement Engage economic and land use forecasters Develop a strategy to measure emissions Use advanced service coverage measures to more comprehensively understand market
7. Trade-offs, negotiation, and choice	Involve MPOs in regional decision making Develop balance sheets to illustrate costs and benefits for multiple stakeholders Work with adjacent transit agencies to develop integrated fare structure and service plans Refine concepts to build consensus
8. Implementation and monitoring	Provide dedicated funding for access improvements Collect data and monitor the results of any improvements to inform future decisions

uniformity to the solutions that are applied. Planning for access to transit does not have to be ad hoc, and may be approached through an overall planning process that helps organize activities and provide uniformity to the solutions that are applied. Organizing agency thinking about station access planning at the beginning of the process can illustrate how commonalities among individual stations can be used to form a unified process.

Identifying needs at a detailed level helps to develop a better understanding of the situation and to link to potential solutions. In so doing, transit agencies can broaden their selection of improvement options and more clearly consider the applicability of solutions from one location to another.

As a result, transit agencies can sort their station issues more clearly, see commonalities across the board, and make better use of available options. Moreover, a transit agency ought not to overlook concerns that do not directly impact the organization or its service, allowing other stakeholder concerns to go unnoticed. Step 2 seeks to ensure that this collaboration takes place and that these concerns are identified.

**Step 2: Establish a Collaborative Environment**

The nature of station access planning requires participation by many stakeholders, and creating a collaborative environment early in the process is essential to success. Fostering collaboration among different operating entities can help achieve a coordinated system. Creating a coordinated system can be elusive, but a collaborative environment is a key step in succeeding. Several attributes, discussed below, support a collaborative environment.

*Acknowledge Interrelation*

Transit agencies should acknowledge the inter-relatedness of station access planning decisions among transportation modes and other elements of the community’s structure. There may be collateral impacts of a decision regarding access to a transit station. For instance, Exhibit 2-4 summarizes some of the potential impacts associated with station access improvements. The positive effects should also be identified. For example, feeder buses can reduce parking requirements and serve the mobility disadvantaged. Park-and-ride facilities extend the reach of rapid transit lines and reduce total vehicle-miles of travel.

*Identify and Include all Stakeholders*

Stakeholders generally include cities, regional and state governments, bicycle and pedestrian advocacy groups, ADA advocacy groups, business districts, and neighborhood associations.

**Exhibit 2-4. Station access mode interrelationships: impacts and issues.**

Access Mode or Factor	Potential Impact/Issue	
	Impact on other access to transit station mode	Impact on other elements in the community
Feeder bus	Need to widen streets or change traffic signal timing, making pedestrian access to transit stations more difficult (longer intersection crossing distances) Buses may interfere with auto access	Noise pollution and air quality during rush hours Upgraded bus stops create concerns about “loitering” for adjacent property owners
Park-and-ride lots	Creates opportunity for bicycle parking Lengthens pedestrian access distance from adjacent land uses	Increased traffic on local streets Noise pollution and air quality impacts
Pedestrian	Wider sidewalks affecting motor vehicle travel lanes	Property owner concerns about trash and losing landscaping or lawns to new or wider sidewalks
Bicycle	Bicycle parking reduces spaces in parking garage available for motor vehicles	Space for bicycle parking reduces number of auto parking spaces
Funding	Competition for funds among modes	Competition for funds with other community needs

Developers and transportation officials from large institutions (e.g., colleges, universities, hospitals, large employers) also need to be a part of the collaborative process. Advocacy is an element in planning for public transit access that can easily be undervalued. Advocates can participate in planning in many ways, including providing individual feedback to service providers, participating on advisory committees, offering testimony, and conducting community walking, bicycling, and bus stop assessments.

### *Establish Shared Goals*

Establish shared goals for transportation, the environment, and economic development. Collaboration starts with shared goals in which the interests of each stakeholder are satisfied. For example, goals for reducing motor vehicle congestion and increasing pedestrian traffic to and around a transit station will serve several interests. The local government will invest fewer resources in roadway maintenance, local retailers will experience an increase in foot traffic, and the transit agency will need fewer park-and-ride spaces. Close cooperation among agencies is necessary to arrive at a set of criteria that is accepted by all stakeholders. Multiple stakeholders will have different and sometimes conflicting objectives. These objectives need to be recognized through the planning and implementation process, and balanced in some way.

### *Understand the Traveler's Perspective*

Transit customers see the transportation system as a single multi-modal system and expect seamless connections between all modes. They want frequent and reliable service with good connections to other transit lines and short walking distances to home and work. They expect the system to work well for their trip. Automobile travelers want convenient parking near stations, and congestion-free routes of access.

## **Step 3: Develop Objectives and Principles**

Long-established goals and objectives that encompass mobility concerns and environmental objectives underlie much of the work of transit agencies. In addition, consideration of station-specific opportunities and constraints will also help determine these goals and objectives. While objectives and principles can be established on a case-by-case basis, having overall station access guidelines can facilitate an impartial process.

Several transit agencies have developed and use formal station access planning guidelines that provide a framework within which the access planning team operates. These guidelines, reflecting the mission of the rapid transit agency, typically define the priority access modes, which may differ between locations. They set forth goal-driven criteria for station access planning and decision making. These criteria should explain why certain factors or features are important. Some guidelines include formal design standards (e.g., walking distances, replacement parking policy where TOD consumes a parking lot). The guidelines can start from transit agency policies, but can be influenced by and updated based on local experience (i.e., what has worked before and what has not).

As an example, Exhibit 2-5 provides a list of a transit agency's station access planning objectives, taken from the BART Station Access Guidelines.

Station access planning guidelines should not be applied rigidly; they need to recognize the needs, values, and context around particular stations. The guidelines define goals and objectives, but should allow trade-offs among the collaborators so that reasonable station access services and facilities can be implemented. They should be flexible and not established as standards.

Flexibility in the guidelines works well if planners and decision makers themselves exhibit flexibility in their actions. This underscores the need for experienced and effective professionals

**Exhibit 2-5. BART station access planning objectives.**

- Improve access via taxis, shuttles, buses, walking, bicycles, and other transit.
- Promote innovative access strategies, such as the station car and the bicycle station.
- Work with local communities to promote transit-oriented development, enhanced destinations, and multiple-purpose stops for reverse commute and off-peak riders (e.g., one-stop shopping).
- Develop carpooling strategies involving preferential parking privileges.
- Improve coordination of transit schedules and fares.
- Explore/promote new technologies to improve access to existing stations, such as the Automated Guideway Transit (AGT) systems.
- Anticipate growth of demand that exceeds station throughput capacity and identify strategies to alleviate anticipated bottlenecks in station throughput capacity.

**Source:** BART

leading the station access planning process—people who understand the mission and have the ability to forge compromises when appropriate to achieve agency goals.

**Step 4: Establish Evaluation Criteria**

Evaluation criteria are identified based on the goals, objectives, and principles selected in the previous steps of the station access planning process. The transit agency must select criteria that evaluate station access options against their potential to achieve the agency's station access goals and objectives.

Station access improvements are generally designed to meet a specific objective, whether it is decreasing cost per rider, maximizing ridership, or encouraging station area development. Depending on the objective, the transit agency must identify evaluation criteria that measure the appropriate indicators. Objective measures are best (e.g., ridership, cost, traffic volumes, mode shares, CO<sub>2</sub> emissions) but all objectives should be covered, and qualitative, descriptive criteria should be used where necessary. Evaluation criteria for potential station access improvements fall into three key categories.

***Ridership***

Measures of ridership (i.e., utilization) of the access mode are a primary evaluation criterion. A poorly utilized mode wastes resources, and becomes a problem as the public becomes aware of low utilization. A related but not necessarily correlated goal for access services is to bring more riders to the rapid transit service. Therefore, where both of these goals are applied, access options must be evaluated not only in terms of the riders they serve but also in terms of the incremental ridership they bring to rapid transit mode. Logically, these two outcomes are typically correlated,

but a new access mode could draw passengers from an existing mode without adding travelers to the rapid transit service.

There are numerous ridership evaluation tools, including an access analysis spreadsheet developed through this research effort. Chapter 5 summarizes these tools. In general, the tools predict ridership based on station, rider, and access characteristics, and the structure of these tools is substantially consistent in terms of variables and formulations. Thus, for most transit agencies, selecting one or a small number of ridership prediction tools should not be difficult.

### *Costs and Revenues*

Capital and operating costs associated with station access are important in planning and decision making. The demand for a given access mode's infrastructure influences the amount an agency will spend to accommodate that mode. A station access service carrying few riders cannot sustain high costs, while one that accommodates many riders can justify a much larger investment.

Moreover, the transit agency's costs of station access infrastructure vary by access mode. Providing park-and-ride capacity requires significant land area, as well as possible payment collection and enforcement, while bicycle parking can be inexpensive and requires relatively little space. This suggests measuring access infrastructure as a cost per rider on the access service and cost per incremental rapid transit rider. Another common measure is the farebox recovery ratio (i.e., the ratio of operating revenue to operating cost). For investment planning, economic measures such as benefit-cost ratio are commonly used.

Some transit agencies have developed integrated measures of costs and ridership by converting riders to revenues. BART developed such an approach to compare (TOD) with use of the same land area for station parking. They use an elasticity-based demand shift model, along with judgmental forecasts, to estimate the ridership consequences of changes in parking supply and price. They convert ridership into revenue and combine the result with land rents from TOD to produce an estimate of the net revenue to the rapid transit operator. This integrated measure is useful for evaluating cost and ridership impacts of TOD parking trade-offs, but other factors, particularly local impacts, will also be important in making access service decisions.

### *Local Strategies and Impacts*

The most focused consequences of station access will be on local communities surrounding the stations. These impacts may be positive (e.g., congestion relief or improved community access to rapid transit) or negative (e.g., increased congestion, noise). In some cases, local concerns may extend to the relationship between transit station access planning and community development strategy: new access service may support or oppose local development plans and desired community characteristics. Consideration of these local strategies and impacts are critical components of the access planning process. Community concerns can be classified into four categories: goals, community capacity, access to the station, and vulnerabilities.

- **Community Goals**—A fundamental concern in rapid transit station access planning is the compatibility between station access design and local community goals. If a community sets its sights on making much greater use of non-motorized modes—becoming a walking and biking community—then the station access design should recognize those goals. Some communities welcome the potential for increasing development near the station as a desirable economic benefit, while other communities do not wish to see any increased activity in order to preserve the existing community character. Helping communities become what they want to (and can reasonably) be is a way of establishing a productive partnership between the rapid transit agency and local governments. The challenge is to balance present needs with future goals and, in the process, help the community fulfill its goals.
- **Community Capacity**—Community capacity to accept new access facilities and services is divided into two categories: (1) land availability for facilities, including parking, terminals,



bicycle facilities, and access roadways; and (2) roadway capacity to handle changes in traffic demand for all important access modes. Land availability must be viewed from the perspective of both the absolute amount of land needed compared with what exists and might be acquired, and from the perspective of community goals for land development near stations: the nature of the current land use (compatibility issues), what the community desires, and what the community will tolerate.

The impact of station access alternatives on roadway capacity and congestion near stations is a critical decision factor in many settings. These impacts may come in the form of community benefits through reduced reliance on the automobile as a result of demand management (e.g., pricing or limiting parking) and providing alternative services (e.g., bike, walk, and feeder transit). Alternatively, if the transit agency adds park-and-ride capacity, the neighborhood around the station may experience more traffic. It will be important to determine whether the street network can safely and effectively carry additional vehicles while accommodating both pedestrian and bicycle traffic.

While station area congestion is an important issue to local communities, it may be of little or no interest to a regional service provider (although difficult access may discourage passenger usage). This observation illustrates the important notion that different stakeholders have different interests in the outcomes. The planning process should respond to these differing interests by introducing the issues early and addressing them effectively through participative planning that engages local agencies.

- **Community Access to the Station**—Rapid transit station access planning must consider the station access needs of the community surrounding the station. These needs will be dependent on land use (density, mix, housing types), demographics (family size, income, employment patterns), and other factors that may change through the planning time horizon. That change may be a result of natural changes over time, or as an outcome of local policy actions mixed with the impacts of the rapid transit service. Thus, it is important to consider local access needs as an evolving issue. The nature of those future needs should be determined through a collaboration of local and regional planning.
- **Community Vulnerabilities**—Community vulnerabilities include sensitive land uses, areas where increases in traffic may cause special safety concerns, historic places, and public open space. Special populations, such as children, the elderly, people with disabilities, and minority populations, may warrant special attention in planning and decision making. It will be important to address such vulnerabilities in both access service design and in the evaluation of alternatives. Much of this effort will be qualitative, and collaboration with local decision makers will be important.

The collaborative process should work to limit the criteria set to the essential few, so that it is possible to understand the alternatives within the framework of the criteria. Ideally, this means 10 or fewer key criteria. Sample objectives with corresponding evaluation criteria are summarized in Exhibit 2-6.

Data collection is an important factor to be considered when establishing the evaluation criteria. Throughout the transit industry, there is a need for more comprehensive data collection programs to support evaluation criteria. Data collection should be conducted regularly, and include information on access mode shares by station, parking utilization, and other information necessary to inform planning decisions. In addition, data collection programs should seek to obtain more qualitative information on such items as neighborhood plans, goals, and priorities.

### **Step 5: Build a Rich Set of Appropriate Options**

Station access plans should reflect the needs and opportunities of individual transit stations, reflecting the station location, pedestrian and bicycle connections, local transit routing, and

**Exhibit 2-6. Evaluation criteria by goal.**

Objective	Evaluation Criteria
Maximize Revenue	Cost per passenger Cost per new passenger Farebox recovery ratio
Maximize Ridership	Monthly station boardings Daily linked trips Passenger-miles traveled
Economic Development/TOD	Station area land value Station access mode share
Reduce Environmental Footprint	Non-auto access mode share Greenhouse emissions generated
Enhance the Local Community	Aesthetic impacts Station area congestion

overall roadway network. Land availability, land costs, existing land uses, and future development plans will also influence improvements. The following guidelines can be used when developing station access options:

- **Consider All Modes.** Transit agencies have a rich set of options from which to select, which is demonstrated by the wide range of solutions found across the United States. The approach taken by many agencies, however, is very often based on a single mode, such as a park-and-ride utilization survey or a bike parking study, which limits the range of options. A multi-modal approach that seeks to balance the modes of access with the goals and objectives may provide the most flexible and robust solution.
- **Address Existing and Future Needs.** Identifying options for existing and future needs ensures that the transit agency is addressing short-term needs while preparing itself for future demands. The demand presented by future needs may influence decision making about existing issues, which is critical for sustainable system growth and development.
- **Consider Station Access in Route Alignments.** Station access planning is often conducted after the high-capacity routing is established and stations are located, which can lead to suboptimal results. Considering access and ridership in the context of station and service planning affords the opportunity to maximize the benefit of potential station area features and development, including connectivity and land use.
- **Integrate Community Design into Station Development.** Incorporating local context and design elements into station planning can encourage more favorable station access features. Effective transit stations are seen by the community as an asset, not simply a means to board a bus or train.
- **Coordinate Station Access Design with Land Development.** Transit stations in urban, walkable environments can emphasize pedestrian connections to maximize the benefit of the area's land use. Similarly, high-quality and convenient feeder bus access is more appropriate at stations with less direct pedestrian connections. In addition to infrastructure and connections, transit agencies should recognize a station's function based on surrounding land uses. Stations primarily serving commercial office buildings will require much different access designs than those serving sports stadiums.

Drawing on the preceding steps, various improvement opportunities can be developed along with associated constraints. Options to be explored can include adding station entrances; providing weather-protected walkways to bus terminals and parking facilities; improving bus service frequency and coverage; expanding parking spaces; relieving recurrent traffic congestion; and fostering TOD.

## Step 6: Predict Outcomes and Apply Criteria

After identifying the objectives and evaluation criteria, and having established a set of options, transit agencies need to predict the outcomes of the improvement options and compare those outcomes against the criteria. Accurate prediction of station access improvement outcomes allows agencies and partner stakeholders to effectively evaluate alternatives. The following is a summary of the existing state-of-the-art of predictive and analytical tools.

- **Improved Travel Demand Modeling Tools.** At present, travel demand models generally do not do a good job of evaluating transit access alternatives. Transit agencies should work with metropolitan planning organizations (MPOs) to develop more sophisticated models that address the questions that decision makers have. Metra (Chicago) uses a model to predict access mode shares to each of its stations, although its methods are simplistic and only differentiate between auto and non-auto station access. More sophisticated models could predict ridership impacts of station access alternatives.
- **Tools to Assess TOD and Parking Replacement.** Transit agencies are developing specialized tools for analyzing the impacts of TOD at stations. BART uses a spreadsheet-based tool designed to weigh the economic and ridership trade-offs between various station area development and parking supply alternatives. By studying alternative development scenarios at stations, analysts are able to estimate what level of parking and development investment will yield the greatest level of benefit to BART, partner transit agencies, and local municipalities. Ridership impacts include riders lost from reduced parking and riders gained through TOD. Financial impacts include changes in parking revenue and the ability of new development to pay for itself through rent.
- **Engage Economic and Land Use Forecasters.** The land use and economic impacts of transit investment are generally accepted, though difficult to measure and predict. Partnering with economic forecasters can provide the opportunity to estimate these future impacts. This can be of particular value when presenting alternatives to partner agencies or the public, as these impacts can justify upfront expense for long-term gain.
- **Emission Measurement Tools.** Although use varies by jurisdiction, environmental benefits are becoming more important across the United States as an evaluation criterion. With transit seen as a major opportunity for enhancing sustainability, transit agencies and affiliated stakeholders will benefit from a quantitative evaluation of the environmental benefits for a variety of alternatives.
- **Advanced Service Coverage Measurement.** Service coverage area is a standard performance measurement for transit agencies that defines the catchment area for transit passengers and can help agencies determine the value of a station or line and evaluate its performance. However, a basic air-distance buffer tends to overlook nuanced station area attributes which may determine ridership access, particularly access mode choice. Advanced methods of measurement, particularly pedestrian and bicycle level of service, are available and can improve an agency's understanding of its service area.

A detailed review of existing predictive and analytical tools, along with a description of the high-level planning tool developed as part of this research are provided in Chapter 5, Travel Demand Considerations.

The outcomes of the predictive models for the base case and each option may be summarized and presented to the stakeholders for discussion and review. The strengths and weaknesses of each option against the criteria should be clearly identified, painting a future picture of the station area under each scenario. At this stage of the process, one or two preferred options may emerge that can be carried forward to the next step.

## Step 7: Identify Trade-offs, Negotiation, and Choices

This step requires close collaboration among the transit agency, the surrounding community, and possibly private developers. Compromise is an essential feature of this collaborative decision

**Exhibit 2-7. Conceptual balance sheet example.**

Outcome measure	Regional Agency		Municipality	
	Benefits	Costs	Benefits	Costs
Ridership	Increased transit ridership	N/A	Improved transit access for residents	N/A
Street traffic (congestion)	Reduced freeway congestion	N/A	N/A	Increased local congestion
TOD	Development opportunities within parking structures	Fewer long-term TOD opportunities	Development opportunities within parking structures	Fewer long-term TOD opportunities
Fiscal Impact	Revenue from operation of park-and-ride facility	Capital costs Maintenance and operation costs	Shared parking opportunities Sales tax from commuter purchases	Reduced property/ sales tax revenue Fewer station area development opportunities
Environment	Improved air quality	Limited reduction in fuel consumption	N/A	Aesthetic impacts of parking lots

making. Exhibit 2-7 shows a conceptual balance sheet summarizing costs and benefits for a hypothetical regional agency and local jurisdiction associated with increasing park-and-ride capacity.

Note that not all trade-offs occur between transit agencies and local jurisdictions; other sets of stakeholders may view options differently. For instance, integrating transit fares to facilitate riding feeder bus to the station may require substantial negotiation between adjacent transit agencies to develop cost-sharing. Some transit agencies may find this an unacceptable option (due to potential losses in farebox revenue), while passengers find it very desirable.

After carefully weighing the available options and analyzing outcomes and impacts, agencies and stakeholders must ultimately decide on transit station access improvements. The results of the evaluation effort will almost always lead to revised designs, or even new options. In some cases this may mean using the information gathered to reevaluate scenarios and run new analyses. Following these steps helps to ensure buy-in by all the relevant stakeholders, thereby providing the best chance for success. Not every process will result in a station access plan that meets the expectations and desires of all stakeholders. However, through an open and collaborative process based on clearly identified objectives and criteria, it is possible to develop an option that is accepted and can move forward to implementation.

### **Step 8: Develop, Implement, and Monitor the Recommended Plan**

Once the preferred option has been selected, the project moves into development (planning and design) and implementation. It is critical that the agreements reached in selecting the final option are carried through into the implementation. If it becomes clear that the selected option cannot be implemented as agreed, the project should return to the trade-off and negotiation

phase of the process (Step 7). In rare instances, it may even be necessary to develop a new set of options (Step 5) and go back through the process with the stakeholders.

Providing funding for a station access planning program is an important element for success. Where possible, agencies should identify ongoing funding for station access improvements to ensure that concerns can be addressed and implemented over time. Understanding the likely availability of future funding will also help choices align more closely with fiscal reality. For example, BART has historically dedicated a portion of parking revenue to access improvements.

Finally, implementation of access improvements should be accompanied and followed-up by a comprehensive data collection, evaluation and monitoring program. Data collection should include ridership, access mode share, method of fare payment, on-time performance of feeder service or other data dictated by the evaluation criteria. The improvements should be formally evaluated against the initial goals and objectives (Step 3) and the evaluation criteria (Step 4), typically one or two years after implementation to allow time for travel patterns to change. After the formal evaluation, data collection should continue for monitoring purposes. Such monitoring will allow agencies to understand the impacts of various access improvements and will provide valuable local information to inform future decisions.

# Insights from Transit Agencies

Eleven case studies provide insight into the strengths and weaknesses of station access planning. The case studies looked at the organizational process and elements of station access planning from two perspectives: (1) agency-wide policy perspectives and (2) the applications of those policies to specific stations. Exhibit 3-1 lists the case study transit agencies and the steps of the station access planning process, as defined in Chapter 2, that were addressed in each case study. The case studies include transit systems that are improving station access in long developed areas, relatively new rail transit systems transitioning from park-and-ride dependence to joint development opportunities, agencies with well-developed station access planning programs, and transit agencies with few access guidelines, but a willingness to work collaboratively with stakeholders.

This chapter provides the policy and planning lessons learned from the case studies as well as key highlights specific to each case study. Appendix E provides the full case studies.

## Elements of Successful Station Access Planning

The case studies identified nine primary areas that are considered by transit agencies as part of their station access programs:

- Local station area context
- Collaboration with local and regional stakeholders
- Local and private concerns
- Station access planning guidelines
- Data requirements
- Predictive and analytical tools
- Short- and long-term cycle station access planning
- Performance tracking and evaluation
- TOD policy

### Local Station Area Context

An important challenge is that both outcome and process success—particularly outcome success—depend substantially on a given station’s setting, defined as those external factors that affect the results but are subject to only limited control by the planning process. Contextual factors include: rapid transit and station characteristics; existing land use; available land; market demand; demographics; spacing, continuity, and connectivity of the pedestrian circulation system—including the presence of sidewalks; structure of the regional transportation network; patterns of congestion; and community politics, goals, and plans.

**Exhibit 3-1. Case study topic area summary.**

Case Study Agency	Process Step							
	1	2	3	4	5	6	7	8
BART			✓			✓	✓	✓
LA Metro			✓		✓			
MARTA			✓			✓		
MBTA	✓		✓	✓				✓
Metro-North	✓	✓						✓
NJ Transit		✓	✓			✓	✓	✓
OC Transpo		✓	✓			✓		✓
RTD Denver			✓				✓	✓
Sound Transit	✓	✓	✓	✓				
TriMet	✓	✓	✓				✓	✓
WMATA	✓	✓	✓	✓	✓	✓	✓	

## Process Steps:

1. Identify the Need
2. Establish a Collaborative Environment
3. Develop Objectives and Principles
4. Establish Evaluation Criteria
5. Build a Rich Set of Appropriate Options
6. Predict Outcomes and Apply Criteria
7. Trade-offs, Negotiation, and Choice
8. Develop, Implement and Monitor Recommended Plan

The context has the power to cause or impede success of the station access planning process and its outcomes. Practitioners must understand contextual characteristics in station access planning to set expectations at a realistic level, adapt the planning process and its results to fit the context, and address opportunities to influence the context itself where feasible. For example, restrictive zoning ordinances might be relaxed or modifications to the regional highway network may be introduced.

### Collaboration with Local and Regional Stakeholders

The transit agency is the key participant in the cooperative station access planning effort. But as crucial as station access services are to the transit agency, it should plan the access with many other groups (see Exhibit 2-1 in Chapter 2) including roadway agencies and the private sector. Station access planning is a collaborative process that should include feeder bus service providers, local jurisdictions, and stakeholder groups. Collaboration and cooperation is essential. Rapid transit agencies must work with such partners, must engage in ongoing collaboration (because station access needs and the external factors that affect them are not static), and must be proactive in reaching out to partners, even those that may be disinterested in rapid transit access planning.

These four steps are essential to balancing participant interests:

1. **Develop strong and open relationships** with (a) local governments and transit service providers; (b) roadway agencies; (c) developers who may own and operate land near stations, or

who may engage in development projects that will or could benefit the transit agency; and (d) residents and property owners in the station area.

2. **Maintain these relationships.** The best way to accomplish this depends on each situation's needs and opportunities. The kinds of tactics that have brought success to the case study transit agencies include establishing interagency committees for sub-regions or specific stations; developing a stable group of access planning staff within the transit agency who become known to local leaders and are familiar with local values and issues; assigning transit agency personnel (rather than consultants) to spend time in the communities on access planning outreach; and assigning specific agency professionals the task of negotiating agreements with local governments and developers.
3. **Have appropriately skilled station access planning professionals.** The people involved should have expertise in transit and traffic operations, parking, pedestrian design, and station design. The leaders of collaborative efforts must be skilled at communicating and collaborating with counterparts in other agencies, with members of the community, and with developers. They need substantial local knowledge, a thorough grounding in the transit agency mission, and familiarity with station access planning guidelines and policies. Station access planners working on TOD projects should know where their flexibility lies and should have some real power to negotiate a solution. An organizational structure where the station access planning decisions are made at the board level may make it more difficult to seize important opportunities.
4. **Define and publicize the mission and goals of the transit agency in the context of local goals and values.** Building the case with other local agencies that the regional mission can be attained while achieving—or at least respecting—local goals and values is critical to success. Local and private resistance to, or disinterest in, station access planning activities usually comes because these entities do not see rapid transit services—and therefore station access—as being relevant to their own needs. Making the case for transit while protecting and promoting local values is essential to get local buy-in to access planning goals and plans. That buy-in is necessary to provide the access services and arrangements required to deliver seamless services to riders, which, in turn, is essential if the transit agency is to achieve its mission.

## Addressing Local and Private Concerns

While compromise is an essential feature of collaborative decision making, the research team observed cases where this simply doesn't work. Some communities, developers, or land owners may not be willing to compromise to ensure reasonable and convenient station access for rapid transit passengers. For example, in Denver a commercial property owner opposed providing access to an adjacent light rail station. In that case, regional pressure led to compromise. In such cases, the transit agency may find success in negotiations, trade-offs, or compensation for the resisting entity. Flexibility in the application of adopted access guidelines may be required to allow this type of negotiation to reach a compromise. In some cases, it is in the best interest of the transit agency to redirect its efforts to other settings, potentially moving a station to an area with greater transit support.

## Station Access Planning Guidelines

Several case study transit agencies have developed and used formal station access planning guidelines that provide a framework within which the access planning team operates. These guidelines, founded on the mission of the transit agency, typically define the priority access modes, which may be different in different locations. They state goal-driven criteria for station access planning and decision making. The criteria should explain why certain factors or features are important. Some guidelines have formal design standards (e.g., walking distances, replacement parking policy where TOD consumes a parking lot). The guidelines may start from established



agency policies, but over time they are influenced by and updated on the basis of local experience (i.e., what has worked and what has not).

The risk associated with station access planning guidelines is that they may be applied rigidly, ignoring the needs, values, and context around particular stations. Representatives from transit agencies with specific guidelines underscored the importance of flexibility. Guidelines should not be standards. They should define goals and criteria, but they should allow trade-offs among the collaborators so that reasonable station access services and facilities can be implemented.

## Data Requirements

Comprehensive and timely data are an important input to the station access planning process. The necessary information will vary, whether an access at an existing station is to be improved or a new station is to be developed.

Station access planning decisions benefit from information on existing access patterns (e.g., mode of access, origin locations, available travel options, perceptions of the access experience, preference improved services). Such data traditionally come from collection and analysis of periodic intercept surveys. Recently, fare card data has been mined to understand home location (for registered fare cards) in relation to first station boarded to predict mode of access. Geographic Information Systems (GIS) analyses of origin locations can give a useful picture of current patterns and potentials for improved services; Exhibit 3-2 shows an example of how BART maps the home locations of participants in its reserved parking program at stations. Archiving data is important to support trend analyses in the future. Surveys should examine access to and from home workplaces and other activities. For instance, roadside intercept/postcard surveys at freeway on-ramps can provide useful information on non-transit users.

Station intercept surveys do not, however, provide information about potential riders who might not be using the rapid transit service. More expansive and costly data collection efforts are necessary to capture this market. Data from the U.S. Census Bureau's American Community Survey and the associated Census Transportation Planning Products can provide an efficient means of understanding this broader market. However, detailed travel behavior can only come from more specialized surveys (e.g., the general household travel surveys that most MPOs collect, about once each decade).

Most transit agencies obtain demographic and land use information for people and activities within a one-half to one-mile radius of the transit station. Car ownership and worker information is useful in assessing potential station ridership.

Data assembly and collection activities should also address the supply side. This is especially important where the transit agency does not provide all of these services. Important data elements include the quantity and quality of bus services (both public and private), and the pricing and utilization of auto and bicycle parking. Many transit agencies (e.g., BART, WMATA) have an increasing number of shuttle services at outlying stations that serve remote employment centers and other major attractors. In many cases, these services are provided by private entities, making it difficult for transit agencies to track the services provided. Transit agencies that perform regular inventories of shuttle services and maintain contacts for each service are better positioned to implement access improvements (e.g., adjusting circulation for shuttle transfers at the station).

Spillover impacts—parking, congestion, safety, and air quality—are another target for data collection because they have direct effects on community and private collaborators in the access planning process. Concerns about spillover impacts may bring local governments into the station access planning process.

**Exhibit 3-2. Example of reserved parking program participant mapping for BART's San Leandro Station.**

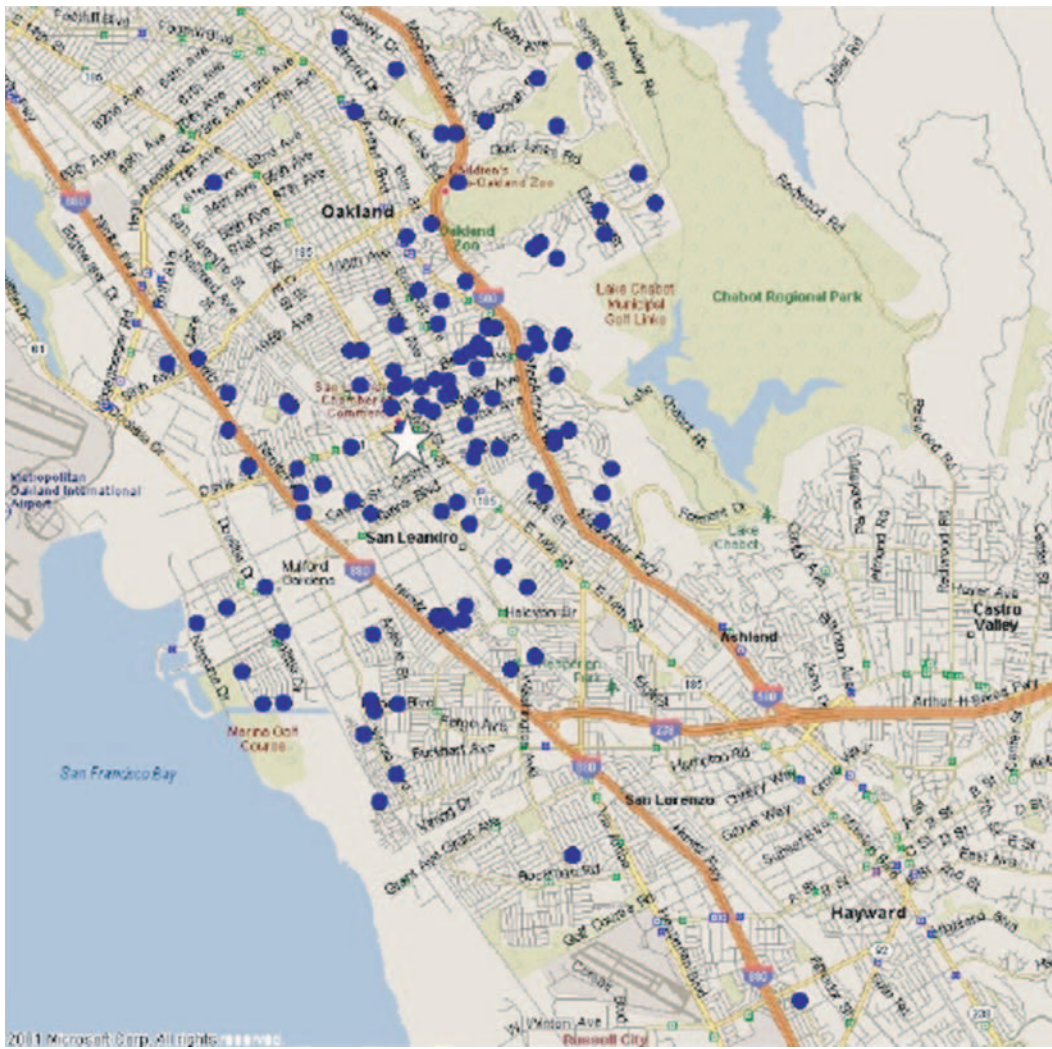

Source: Richard Willson

Information should be assembled on roadway characteristics in the station environs. Desired information includes roadway geometry, traffic controls, traffic volumes by direction, and service levels.

### Predictive and Analytical Tools

Predictive models are important to answer critical “if/then” questions in support of station access planning (e.g., to predict ridership for an access mode or parking response to pricing changes). Traditional models used for regional transportation planning may not be sufficiently sensitive or detailed enough to evaluate station access mode options. Several transit agencies use proprietary models usually developed by consultants. This is a critical gap in available tools, particularly given the important role that station access services play in the success of major capital investment in rapid transit systems.

Some transit agencies have developed tools specifically for analyzing trade-offs involved in planning TOD, such as the consequences of relaxing parking requirements or changing the

locations of parking. One example is BART, which has developed a spreadsheet tool to test the impacts of alternative station development scenarios, with an emphasis on assessing the trade-offs associated with providing commuter parking versus encouraging TOD. Financial impacts analyzed include changes in parking revenue and the ability of new development to pay for itself through rent. Thirteen model inputs are used, including current access mode shares, parking costs, elasticities, and land values. (This spreadsheet has not been published, but was obtained directly from BART.) However, its relevant findings were incorporated into the spreadsheet tool developed by this research.

A review of existing predictive and analytical tools is provided in Chapter 5, while Appendix C presents the high level planning tool developed as part of this research.

## **Performance Tracking and Evaluation**

Collecting data on performance of station designs and access services is useful for providing a basis for evaluating projects, generating local learning, and developing success stories. Local learning has high value because such information generally has higher credibility—and often greater validity—than measures of outcomes achieved in other locations.

RTD (Denver) maintains a database on park-and-ride lot activity in relationship to parking fees. This database allows the agency to understand if the parking fees are having the intended effect of shifting patronage from over-utilized to under-utilized lots, or diverting to other modes of access.

In addition, RTD publishes an annual TOD Status Report describing its TOD projects and their success. This means collecting data to determine the outcomes from specific station access planning and TOD actions. Similarly, NJ Transit contracts with the Voorhees Transportation Center at Rutgers University to track and evaluate TOD near NJ Transit facilities. Evidence of success, as well as failures and actions to remedy them, can be the basis for future planning, discussion, and negotiation. This has proven useful not only for evaluating TOD projects, but also for promoting new TOD projects by showing examples and success models.

## **Short- and Long-term Station Access Planning**

Station access planning is necessary for both existing and new rapid transit service. Established services need periodic reviews and continuous station access planning activities because markets and services change. Parking fills up, rapid transit ridership creeps up (or down), and needs for new access services or increased capacity arise. In addition to the changes on the transit system, the area surrounding stations can experience dramatic changes, often in the forms of increased density and traffic congestion in the station vicinity. A regular program of data collection can track these trends and lead to changes in the design of stations and access services.

New rapid transit lines require a comprehensive assessment of opportunities, benefits, costs, and impacts. Considering the long-term context of a station while in the initial design phases gives the transit agency the ability to plan for shifts in station access modes over time. TriMet successfully used this strategy in the design of a transit center and surface park-and-ride lot that were in an undeveloped area when the station was opened. More than 10 years after the station opened, development intensified around the station. The station was redesigned to include a community college and workforce center; a portion of the park-and-ride space transitioned to shared use parking. Ridership generated from the development at the station more than offset the limited loss of parking.

The planning process does not vary much among the different rapid transit modes: commuter rail, heavy rail, light rail, and bus rapid transit. Whatever the mode, rapid transit stations have similar needs, driven more by specific settings than by transit technology.

## Station Area Development

When rail transit was first developed, walk access was a primary mode to get to the station. Many stations were located right in the middle of small satellite city business centers, with limited parking access but strong walk access to homes, jobs, and shops. With the shift to a suburban automobile culture, transit stations began to shift away from walk access and place more emphasis on auto access.

Recently it has been recognized that increasing the density of development around stations may be a cost-effective method of increasing transit ridership and reducing impacts on the surrounding neighborhoods and transportation network. TOD has become a leading station access planning tool.

Planning for TOD is perhaps the most complex aspect of station access planning because it invariably involves several different entities with widely differing interests. Beyond the transit agency, these include local governments, the local community, and private developers. The agencies with the most active joint development programs (LA Metro, BART, and WMATA in the case studies conducted here) have found that agency-wide joint development policies are beneficial for negotiating solutions that help achieve agency goals. These policies define development requirements and procedures, and provide criteria for evaluating competing development proposals. The role of TOD in station access planning is discussed in depth in Chapter 11, TOD and Station Access.

## Improving Station Access Planning

The case studies indicate that transit agencies have a wide variety of policy, process, and evaluation tools available to make informed decisions about station access. However, the degree to which industry best practices are adopted varies widely among transit agencies. Research shows five key gaps that can adversely affect the effectiveness of station access programs and should be addressed.

1. **Collaborative values and skills.** It is essential to engage a wide variety of stakeholders to develop effective station access solutions for rapid transit, as many improvements cannot be implemented by the transit agency alone. However, many transit agencies face community resistance in embracing transit stations and engaging in dialogue. Thus, there is a need for more proactive engagement practices within transit agencies to: (1) identify willing partners; (2) establish strong relationships with local jurisdictions; and (3) accept compromise when it is in the transit agency's best interest to do so.
2. **Timely and accurate data.** Timely information on station access mode characteristics is essential for effective service and facility planning. Effective data collection for station access planning should include up-to-date information on the costs and usage of providing various access facilities (e.g., feeder transit, parking facilities, bike parking). In addition, periodic rider surveys to understand access patterns and modes at individual stations are desirable to identify rider preferences and to monitor trends. These datasets provide objective information for planning, decision making, and operations. While some agencies collect most or all of these data, many do not. In particular, many agencies have only anecdotal or outdated information on the access mode characteristics at individual stations, making evaluation of current and proposed access service difficult.
3. **Methods and tools.** Relatively few of the case study agencies have established evaluation methodologies or have tools to assess the impact of access improvements (e.g., estimating the effects of a particular TOD strategy on ridership). Regional travel demand models are not sensitive enough to local contexts in most cases to estimate access mode shares accurately, but few other options exist at present. Some agencies have developed rules of thumb, spreadsheet

tools, or even proprietary ridership models (in the case of BART), but the lack of tools to answer many access-related questions remains.

4. **Trained personnel.** Effectively identifying and implementing access improvements requires transit agency staff with a thorough understanding of its agency goals, station access principles, process tools, and local context. Staff must be dedicated to dealing with station access issues and local stakeholders on a regular basis to achieve this level of understanding, and must have negotiation and compromise expertise. Staff knowledge of traffic engineering and land use planning is also desirable.
5. **Resources to support implementation and operations.** Adequate funding for access improvements is critical. Wherever possible, transit agencies should identify money for both capital improvements (e.g., parking expansion) as well as operating expenses (e.g., additional feeder transit service). Implementation funding should include resources to monitor program effectiveness in order to inform future decisions.

The gaps identified above could be addressed in several ways. Some require action on the part of individual transit agencies, while others more likely require pooled actions on an industry level (e.g., APTA, TCRP research). Suggested guidelines follow:

- Dedicate transit agency staff and funding to collect the data required to support station access decisions. Transit agencies should also explore opportunities to partner with other agencies on existing data collection efforts, such as contributing money to a regional household travel survey to address questions of transit station access. For instance, data mining of electronic fare payment cards is a cost-effective way to obtain rider information for agencies with automatic fare card systems.
- Develop more comprehensive evaluation tools to predict outcomes of various access-related actions. Few transit agencies have objective tools to estimate parking demand, the effect of TOD on ridership, and cost-effectiveness of feeder buses.
- Encourage professional development training. Transit agency staff at a variety of levels would be trained on both process and tools for station access planning. This would include emerging trends and best practices in station access planning, and community and stakeholder involvement techniques on transit operations. For instance, a National Transit Institute course focused on tools to improve access to transit stations may be valuable.
- Identify dedicated funding for access improvements. For example, capital improvement bond measures can include station access planning and improvements, as was done with Sound Transit's ST2 initiative. Capital development plans and designs for new rapid transit services and service extensions should include funding for station access infrastructure. Including station access planning into transit and regional planning documents (e.g., Transit Development Plans and Long Range Transportation Plans) provides the transit agency with "shovel-ready" projects should funding become available.
- Encourage local community and transit agency buy-in early in the planning process for new stations to achieve consensus on the ultimate build-out of the station site.

## Insights from the Case Studies

This section provides specific lessons learned from each of the eleven case studies. Appendix E provides detailed case study summaries.

### BART — San Francisco

The Bay Area Rapid Transit District (BART) operates an extensive high-speed rapid transit system that connects downtown San Francisco with East Bay and Peninsula communities. The agency has developed station access guidelines. BART's experiences with station access planning include the following:

- Developing station access guidelines provides value in supporting collaborative planning efforts. At the same time, guidelines must remain flexible to be successfully applied.
- Timely data on access mode characteristics is critically important for effective service and facility planning. Periodic intercept surveys of access modes and preferences supports trend-tracking and provides objective information for planning and decision making.
- It is important to address trade-offs between TOD and park-and-ride facilities from all perspectives (e.g., the developer, the transit agency, the local community). Balancing these interests may require subsidies.
- Locally developed tools, such as BART’s Direct Ridership Model and Parking–TOD trade-off spreadsheet tool, are useful for predicting and analyzing access mode utilization in response to service and facility changes (1).
- Rapid transit agencies need effective means of understanding and coordinating with other local transit agencies and shuttle service providers to assure riders receive seamless services. For shuttle services, it is important for agencies to have an inventory of where shuttles are located, and a contact person at each one.

## LA Metro — Los Angeles

LA Metro operates a heavy rail transit line, three light rail lines, and a busway. In addition, express bus lines use the Harbor and Santa Monica Freeway transitways. This case study found that:

- Access issues and improvement strategies are generally consistent across rapid transit modes, and Metro does not distinguish between rapid transit modes in their policies. This suggests that a transit agency’s station access planning will typically be consistent across rapid transit modes, with differentiation primarily a result of local context in individual station areas.
- Bicyclists vary considerably in their characteristics and trip purposes. A variety of strategies and parking types are needed to encourage bicycle access to transit stations while minimizing the number of full-size (i.e., non-folding) bikes that are brought onto transit vehicles. Development of a Bicycle Strategic Plan has been important to Metro’s success in achieving this goal.
- Joint development at transit stations need not reduce park-and-ride capacity. Metro has maintained—and sometimes increased—commuter parking by incorporating parking structures in joint development projects. However, a subsidy is often required from the transit agency to achieve this goal.
- Agencies with significant joint development opportunities benefit from standardized joint development policies, such as Metro’s Joint Development Policies and Procedures, which establish desired outcomes and evaluation criteria for proposed developments.
- Successful joint development requires frequent interagency coordination, as joint development almost always requires approval from at least two agencies (the transit agency and the local jurisdiction) and often more, such as redevelopment agencies and state departments of transportation.
- Adequate parking for transit riders is essential for ridership in many situations. When TOD takes place, more—rather than less—parking is provided. Parking reductions are made only where they will not inhibit ridership.
- Good pedestrian access is essential. From an urban design perspective, the pedestrian access system should extend the “reach” of the station environment.

## MARTA — Atlanta

MARTA has a two-route (plus branches) heavy rail transit system that focuses on the city center. Findings of this case study include:

- Developing a station typology can allow agencies to better adapt policies to the needs of individual stations, by allowing evaluation criteria and/or goals to vary by stations type. For instance, MARTA varies its parking replacement requirements for TOD by station type.

- It is often difficult in joint development projects to build an amount of parking that effectively balances preservation of park-and-ride ridership, provision of parking for new development, and the desire to create a walkable urban environment.
- Neighborhood shuttle bus services are often more effective at improving feeder access to transit than re-routing longer-distance local bus routes to connect to stations. However, these shuttles are also more expensive to operate.
- There are often opportunities for TOD even in systems with a historical emphasis on drive access.

### **MBTA — Boston**

MBTA operates an extensive system of commuter rail, heavy rail, light rail, and bus rapid transit (BRT) services that have been progressively improved over the last century. Its case study shows that:

- Even transit agencies with older infrastructure and a focus on asset management—rather than expansion—can find significant opportunities to improve access to stations. MBTA’s recent actions include improved bicycle and auto parking, improved bus connections, and searching for development opportunities. Between 2005 and 2010, the MBTA sold or leased rights for more than 50 TODs.
- The success of many station access improvement strategies depends on both transit agency and local jurisdiction commitment, but local jurisdictions vary widely in their commitment to improving transit. Transit agency resources may most effectively be focused on those communities most interested in transit.
- Data on existing access patterns and access mode shares are important even when a transit agency has no specific access mode targets (e.g., to inform modeling to predict parking demand at proposed stations).
- Even in cases where parking fee increases result in lower parking demand, ridership may remain relatively constant, as many riders will switch to other access modes or find parking elsewhere rather than abandon the rapid transit mode. The attractiveness of the rapid transit mode is especially resilient in metropolitan areas with a large regional employment core and constrained (i.e., expensive and/or difficult to find) parking availability in the regional core.
- The long-established policy has been to bring streetcars—and later buses—into elaborate inter-modal transfer stations. In recent decades, emphasis was also placed on providing park-and-ride at outlying heavy rapid transit and commuter rail stations, while still fostering pedestrian and transit access in built-up areas.
- The planned Green Line extension to East Cambridge, Somerville, and Medford will rely on pedestrian use and transit access (2).

### **Metro-North — New York and Connecticut**

Metro-North operates three commuter rail lines between Grand Central Terminal and suburban communities in New York State and Connecticut:

- Commuter rail ridership on Metro-North’s New Haven, Harlem, and Hudson Lines has grown rapidly in recent decades creating parking shortages along all three lines.
- Much parking along the lines is owned and operated by cities and towns. Some of the communities have long waiting lists for reserved parking spaces.
- Metro-North, working with communities and Connecticut Transit, has expanded parking space at several stations in Connecticut. Major parking garages were built in New Haven, Bridgeport, South Norwalk, and Stamford, and a new parking facility is under construction in Fairfield.
- Metro-North is as well-established a transit agency as any in the country, with many of its services nearly 150 years old. Yet even here, the transit agency increasingly sees the need to transition from its traditional focus on drive access and provide more comprehensive multi-modal access options at locations where space is constrained, especially in New York State.

- Many communities provide extensive bus service to stations.
- Enhanced feeder bus service can effectively improve station access and increase ridership at many stations where parking is over-subscribed. Transit agencies that do not directly operate such services can still promote them through effective partnerships with local operators. A free shuttle bus connects the New Haven station with the city center—the focus of the local bus system—and with remote parking garages.
- In some cases, such as Metro-North’s Hudson Rail Link, targeted improvements to feeder transit service can both increase ridership and cover operating expenses. Such a result, however, depends on a high-draw urban core (in this case midtown Manhattan), and may not be generally applicable to many other areas.
- Metro-North’s experience adjusting operations of the Haverstraw–Ossining Ferry to achieve better results allowed it to operate the Newburgh–Beacon Ferry more effectively. This suggests that agency-wide station access guidance that summarizes and synthesizes past experience can enhance station access planning efforts, even at transit agencies that prize flexibility in planning.

## **NJ Transit — New Jersey**

NJ Transit operates an extensive system of commuter rail lines that enter Manhattan or reach Hoboken. The agency also operates light rail lines along the Hudson River waterfront, in Newark, and between Camden and Trenton. The commuter rail lines began more than a century ago and the Newark light rail is an upgraded, long-established streetcar line, while the other two light rail lines are more recent. This case study demonstrates that:

- Guidelines and guidebooks for improving station access and encouraging transit-friendly development are important. However, such guidance will be most effective when supplemented by direct outreach and assistance to individual communities.
- A comprehensive set of complementary station access improvements should be developed as part of any major improvement or expansion of rapid transit service. This work should include identifying locations for parking expansion and proactively working with local communities to prepare for and accommodate increased development pressure in station areas.
- Timely data on station access mode characteristics is critically important for effective service and facility planning. Periodic intercept surveys of station access modes and preferences supports trend-tracking and provides objective information for planning and decision making.
- Partnering with an independent organization to evaluate programs, as New Jersey has done with the Voorhees Transportation Center at Rutgers University for its Transit Village Initiative, provides an objective means to assess program effectiveness, document successes, and make refinements.
- While transit agency and state programs are important, success in promoting TOD at a given station ultimately requires a local jurisdiction that is interested and committed.
- Well-designed transit agency and statewide programs can be effective at promoting TOD, especially when they provide direct funding for improvements (particularly subsidies for constructing structured parking).
- Transit agencies that serve a large number of jurisdictions should dedicate resources to working directly with individual communities that wish to foster TOD in specific station areas.

## **OC Transpo — Ottawa**

OC Transpo has operated a heavily used busway system since the 1970s. Within the past decade, complementary rail transit service has been initiated. Results of this case study include the following:

- Station access issues faced on BRT systems are, for the most part, the same as those faced by rail transit agencies, indicating that rapid transit mode is secondary to the local context in determining station access and ridership characteristics.



- Agency consolidation reduces interagency coordination needs, and can result in significant efficiencies in planning and implementing station access improvements. In the case of OC Transpo, the transit agency was incorporated into the City of Ottawa’s government in 2001 as part of a regional consolidation of governments into a single central city government.
- OC Transpo’s use of extensive public outreach to gauge reactions to potential service restructuring options showed the value of public outreach in alternatives evaluation. Outreach as part of Ottawa’s Transportation Master Plan showed that people were not opposed to additional transfers where connections were seamless and wait times very low. This result contributed to ongoing restructuring and simplification of service to focus less on local buses entering the busway and instead on having passengers transfer from local bus to BRT.
- Established design principles, such as OC Transpo’s Light Rail Design Guidelines, allow station access planning and design to proceed more efficiently.
- A comprehensive parking facilities needs study, such as OC Transpo’s Park-and-Ride Study should: (1) establish policy regarding locations where park-and-ride facilities are appropriate; (2) estimate future demand for additional parking; and (3) identify and screen potential park-and-ride facility locations.
- Ottawa’s strong land use controls have required major developments to be located along its busway system. Several developments have direct pedestrian connections to busway stations.

### **RTD — Denver**

The Regional Transportation District (RTD) operates light rail lines that connect downtown Denver with outlying areas in southwest and southeast suburbs. Much of the southeast line is located alongside I-25. This case study demonstrates that:

- Developing station access guidelines helps support collaborative planning efforts. At the same time, the guidelines must remain flexible to be successfully applied.
- Parking pricing can achieve many goals in addition to simply serving as a potential revenue source, including reducing the number of long-term (all-day and overnight) parkers, and shifting demand to facilities with unused capacity.
- Successful joint development programs require flexibility to adjust to unique market conditions and other constraints at individual stations.
- Maintaining an online TOD database, and preparing periodic summary reports, is a valuable method of documenting TOD in the region and making the case for additional TOD.
- Establishing a permanent Transit Access Committee is a means to ensuring consistent access improvements and joint development projects throughout the system.
- Direct pedestrian access between transit stations and adjacent development is critically important to both transit’s and the development’s success, yet some property owners still resist providing such access.

### **Sound Transit — Seattle**

Sound Transit is a regional transit agency that operates a commuter rail line, a light rail line, a modern streetcar line, and regional bus service. County- and city-based transit agencies provide bus connections to many of Sound Transit’s services. Sound Transit’s station access planning experiences include the following:

- Each community will have a different set of priorities and stakeholders that should be included in the public process. The City of Seattle’s Public Outreach Liaison (POL)—where neighborhood leaders are hired as part-time city employees—is one method to address this diversity of needs.
- It is unrealistic and undesirable for transit agencies to consider stations in isolation from surrounding communities.

- Close coordination with the surrounding community and local jurisdiction is needed to implement new rapid transit service, particularly when the service does not rely heavily on park-and-ride.
- Capital improvement programs targeted at improved station access should focus on more than simply increasing parking supply by addressing the diverse goals that individual communities have for their station areas.
- Establishing policy to support bicycle access while minimizing the impacts of bicycles brought on-board transit vehicles is important in regions where bicycling is a significant and increasing mode of travel.
- Transit agencies benefit from having evaluation criteria connected to agency-wide goals to assess potential station access improvements.

### **TriMet — Portland**

TriMet's light rail system extends in all directions from downtown Portland, Oregon. The system continues to be expanded and a commuter rail line opened in 2009. The TriMet case study shows that:

- Effective public outreach on an individual capital project helps to build regional support for subsequent capital projects. TriMet believes that effective public outreach should start early and be based on grass-roots outreach. Successful public outreach means that formal public hearings are “non-events” because problems have already been resolved.
- Public outreach may be more effective if not contracted to consultants. TriMet has its own community affairs staff to ensure that (1) staff truly represents the transit agency to the public and (2) to maintain continuity of staff throughout the project.
- Having a strong relationship with local jurisdiction, institutions, and developers is critical to the long-term success of station access planning. For example, TriMet's commitment extended to funding a project engineer at the City of Milwaukee to represent the city's interests as part of planning for the Portland–Milwaukee light rail, since the city could not afford to add this staff member itself. This action clearly signaled to Milwaukee that addressing the city's concerns was integral to the success of the project.
- Transit stations and transit activity should be directly integrated into communities through station design and site plans. This commitment is seen in the design of many of TriMet's stations.
- With a regional commitment to providing non-auto access, especially transit-supportive land use, it is possible to develop a successful regional rail system that relies on park-and-ride access for only a small portion of ridership.
- Reducing existing parking capacity to support TOD may require justifying the reduction to FTA if federal funding was used to construct the parking.

### **WMATA — Washington, D.C.**

Washington, D.C.'s Metro system covers the entire metropolitan area and is the most heavily used U.S. heavy rail system after New York City. This case study shows that:

- Developing station access guidelines provides value in supporting collaborative planning efforts. At the same time, guidelines must remain flexible to be successfully applied.
- Timely data on access mode characteristics is critically important for effective service and facility planning. Periodic intercept surveys of access modes and preferences supports trend-tracking and provides objective information for planning and decision making.
- Expanding parking facilities is expensive and requires land that may not exist in many cases. This observation suggests that agencies that expect ridership increases may need to focus on improvements to non-auto access to realize ridership growth.

- Station-specific access studies, funded by either the transit agency or local jurisdictions, are valuable means of identifying and prioritizing access improvement options.
- Transit agencies with significant joint development opportunities benefit from standardized joint development policies that establish desired outcomes and evaluation criteria for proposed developments.
- Transit agency offices that are involved in access planning should be organized to ensure that access planning efforts will be coordinated internally and will provide a more effective process externally. Those involved in access planning at WMATA include planners, real estate, operations planning, rail and bus operations, plant maintenance, parking management, marketing, and government relations.
- Transit agencies should consider the cost-effectiveness of access modes. WMATA is developing the analytical tools needed to determine the cost-effectiveness among access modes to set access-mode goals and make investments.
- Transit agencies can proactively set mode share goals instead of passively calculate mode share projections. WMATA's access mode share priorities are related to comparable goals established by member jurisdictions.
- WMATA has a broad range of station access modes. Pedestrian access dominates in many densely developed areas. However, the system also has large parking garages that directly connect to the regional freeway system.

# Station Typology, Access Modes, and Access Policy Guidance

The access modes used by passengers arriving at rapid transit stations relate closely to the development patterns and densities of each station's catchment area. They also reflect the opportunities available in the station area for walking, bicycling, feeder bus transit, and automobile access (including parking).

This chapter shows the general relationship between station access modes and land use. It sets forth a station typology for commuter rail, heavy rail, light rail, and BRT. It then discusses station boardings and arrival modes and shows the effects of major park-and-ride facilities on station boardings. Finally, it suggests station access policy guidelines based on the typology and characteristics of each access mode.

## General Considerations

Passenger access to rapid transit stations can be provided by several modes. These modes vary by system and station location. On a system-wide basis, they reflect the age and coverage of the system, and the characteristics of the system's service areas.

The multi-modal dimension of individual station access is clearly illustrated by access provisions at the Sierra Madre Station along Los Angeles' Gold Line. A weather-protected footbridge over a freeway (Exhibit 4-1) provides access to the center island station platform. This bridge connects with the fourth floor of a five-story parking garage. Bus stops and bicycle lockers are provided on the first floor of the garage and a pedestrian route to the surrounding area's street network is provided from the garage elevators.

The access mode emphasis at any given station depends upon surrounding land use types and densities, frequency of connecting bus services, street spacing, sidewalk availability and connectivity, and the number of parking spaces provided.

Exhibit 4-2 shows a generalized modal use pattern as a function of distance from the city center (a surrogate for density). There are, however, many site-specific corridor conditions that influence passenger arrival and departure modes. Accordingly, more systematic station classification systems were developed.

## Station Typologies

The project team developed station typologies for each rapid transit mode to provide an overview of the types of stations currently in use in transit systems throughout the United States and Canada. These typologies illustrate general characteristics for stations, including land use intensity, feeder transit connections, parking availability, and the quality of the pedestrian network.

**Exhibit 4-1. Footbridge providing access to Sierra Madre Station, CA.**



Source: Kittelson & Associates, Inc.

The typology described in this paper relates only to physical factors present at transit stations and within the station area (roughly defined as ½ mile, although this may vary by station).

Station types provide a general idea of the attributes and access/egress mode characteristics associated with the different stations and their primary function within the greater transportation system. In practice, stations will rarely fit a given station type exactly; rather, most stations will share the characteristics of multiple types.

Traditionally, most non-CBD transit stations served primarily as trip origins, with passenger destinations located in the CBD. However, as suburban employment increases and transit expands to serve this market, “reverse” and suburb-to-suburb commutes via transit are increasing. To capture the effects of egress planning in the typology, the typology includes both origin and destination non-CBD stations.

**Exhibit 4-2. Conceptual illustration of density’s effect on access mode choice.**

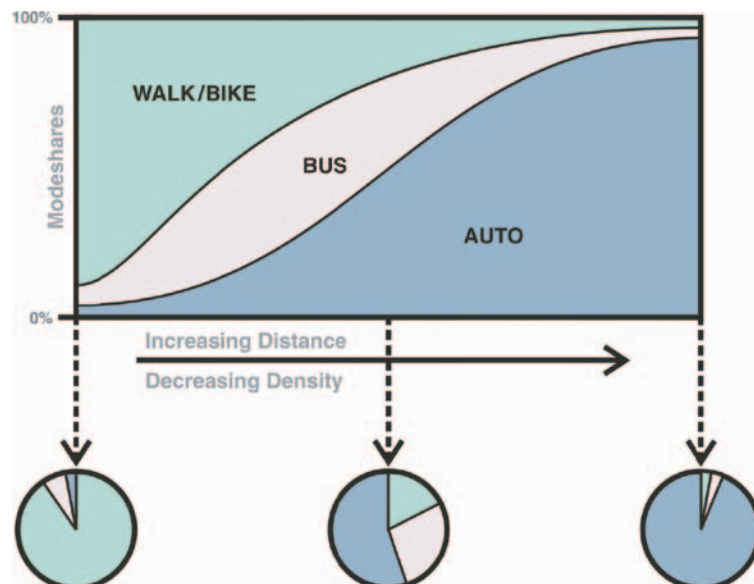

A station typology can help to serve as a starting point for station access planning. In most cases, tools and strategies to improve transit access and egress will only be applicable for a limited set of station types. As a result, successful planning should carefully consider the unique conditions at each individual station.

Stations were reviewed according to eight categories:

- **Housing density**—a characterization of the housing density in the area around the station. This attribute provides insight into the potential riders that live within walking distance of the station.
- **Scale**—average building height in the area surrounding the station. Building scale relates to walkability, density, and activity levels, and helps to illustrate the feel of the station area when combined with some of the other categories.
- **Distance from CBD**—a measure of the typical station type’s location within the metro area. Stations further from downtown will tend to serve a different market than those closer to the CBD. Stations closer to the urban core tend to emphasize pedestrian connections while commuter stations focus on providing enough parking to meet demand. These locational attributes will vary according to transit mode and other land use considerations.
- **Supporting Transit Network**—the level of transit connectivity to other transit services available at the station. This measure identifies how the station operates in the context of the overall transit network and indicates the station’s ability to serve a wide-ranging area.
- **Pedestrian/Bike Access**—a measure of the completeness and attractiveness of the pedestrian and bicycle networks around the station. Well-formed connections for pedestrians and bicycles are important for assuring successful station access.
- **Surrounding Land Uses**—description of the land use mix in the station area. Stations adjacent to different land use types serve different functions.
- **Parking Facilities**—the level of off-street parking accommodation provided at the station type.
- **Access/Egress**—simple classification (Access/Egress/Both) describing the *primary* role of the station in the transportation system. Some stations are located at the “home” end of the journey for most passengers, while others represent the destination. This distinction is important because passengers are more likely to have access to a private vehicle at the “home,” or access station.

A suggested station access typology is shown in Exhibit 4-3. This classification system applies to stations along commuter rail, heavy rail, light rail, and BRT lines. The typology also shows where each access mode should be encouraged. The CBD, which relies mainly on pedestrian access, is included in the urban commercial category.

The table defines station type in terms of land use, density, scale, and distance from the CBD. It describes the surrounding land and use, the pedestrian and bicycle access features of the existing transit network, and the likely availability of parking facilities. Example stations are given for each typology.

The challenge is to place each station into a specific typology. Therefore, in some circumstances, it is desirable to adopt a simplified station typology model. Such an approach stratifies stations into five base types: (1) CBD, (2) urban—medium to high density, (3) suburban low-density, (4) terminal stations (both transit and auto-dependent), and (5) special conditions.

## Examples of Station Arrival Modes

As part of the research effort, access mode data for over 450 rail transit stations at eight transit systems were collected and summarized. Station types were assigned to each station. The weekday daily average percentage of station users (for all trips) arriving by a particular mode was then computed. The results are shown in Exhibit 4-4. Appendix D provides the complete set of access data.

**Exhibit 4-3. Station access typology.**

Station Area Type	Housing Density	Scale (# of stories)	Distance from CBD	Supporting Transit Network	Ped/Bike Access
Urban Commercial	High	>5	0-10 miles	Intermodal facility/transit hub	High-quality network; good connectivity
High-Density Urban Neighborhood	High	>5	0-10 miles	Subregional hub	High-quality network; good connectivity
Medium-Density Urban Neighborhood	Medium	2-5	5-10 miles	Some local bus connections	High-quality network; good connectivity
Urban Neighborhood with Parking	Medium	2-5	5-10 miles	Subregional hub	High-quality network; high-volume roadways may limit connectivity
Historic Transit Village	Medium-High	2-5	10-40 miles	Some local bus connections	High-quality network; good connectivity
Suburban TOD	Medium-High	2-8	5-15 miles	Some local bus connections	Good network within station area, some high-volume roadways
Suburban Village Center	Medium-High	2 – 5	5-15 miles	Subregional hub	Limited connectivity, some high-volume roadways
Suburban Neighborhood	Low-Medium	1 – 3	5-15 miles	Some local bus connections	Limited connectivity, some high-volume roadways
Suburban (Freeway)	Low	0-2	10-20 miles	Employer shuttles, limited bus connections	Isolated, difficult connections
Suburban Employment Center	Low	1 – 3	5-15 miles	Some local bus connections, employer shuttles	Poor connectivity, high-volume roadways
Suburban Retail Center	Low	1 – 3	5-15 miles	Some local bus connections	Poor connectivity, high-volume roadways
Intermodal Transit Center	Low-Medium	1-3	5-15 miles	Intermodal facility/transit hub	Good connections between systems; isolated
Freeway/Highway Park & Ride	Low	0-2	15-40 miles	Employer shuttles, limited bus connections	Isolated, difficult connections
Busway	Varies	Varies	10 – 30 miles	Subregional hub	High-volume roadways, difficult connections
Special Event/Campus	Low-Medium	1 – 3	Varies	Some local bus connections	Limited connectivity with emphasis on special facility
Shuttle Station	Low	0-2	15 – 40 miles	Employer, airport, special event shuttles	Isolated, difficult connections
Satellite City	Low-Medium	1-3	>30 miles	Subregional hub	High-quality network; good connectivity
Legacy	Low	0-2	Varies	Limited connections	Isolated, difficult connections

Surrounding Land Use	Access/ Egress	Parking Facilities	Example Stations	Rapid Transit Modes
Office, residential, institutional, retail, entertainment, and civic uses	Both	No off-street parking	16th Street/Mission (BART) Lloyd Center (TriMet) East Liberty (Port Authority)	Heavy Rail Light Rail BRT
Residential, neighborhood retail, limited office	Access	No/limited off-street parking	Kingsbridge Road (NYCT)	Heavy Rail
Residential, neighborhood retails	Access	No/limited off-street parking	Western – Pink Line (CTA) West Baltimore (MARC) Othello Station (Sound Transit) Euclid Ave/71st St (Cleveland RTA) Hoboken – 14th Street (NY Waterway)	Heavy Rail Commuter Rail Light Rail BRT Ferry
Residential, neighborhood retail	Access	Off-street parking available	Anacostia (WMATA)	Heavy Rail
Residential, neighborhood retail, limited office	Access	Some off-street parking	Greenwich Station (Metro North)	Commuter Rail
Residential, neighborhood retail	Both	Some off-street parking	Bethesda (WMATA) Davis Street (Metra) Orenco Station (TriMet) Tunney's Pasture (OC Transpo)	Heavy Rail Commuter Rail Light Rail BRT
Residential, neighborhood retail, commercial	Access	Some off-street parking available	Downtown Littleton (RTD) Van Nuys (LA Metro)	Light Rail BRT
Residential, retail, limited office	Access	Some off-street parking available	South Bank (PAT) Pleasant Park (OC Transpo) Route 915 - Columbia (MTA) Quincy (MBTA)	Light Rail BRT Commuter Bus Ferry
Varies	Both	Park-and-ride prioritized	Owings Mills (MTA)	Heavy Rail
Office, retail and limited residential	Egress	Park-and-ride prioritized	McCormick Road (MTA) Maple Island (Lane Transit)	Light Rail BRT
Retail, limited office	Egress	Park-and-ride prioritized	Great Mall Transit Center (VTA) Warner Center (LA Metro)	Light Rail BRT
Varies	Both	Park-and-ride often prioritized	Forest Hills (MBTA) Mukilteo (Sound Transit) Bellevue Transit Center (Sound Transit) Hoboken Transit Terminal (NY Waterway)	Heavy Rail Commuter Rail Commuter Bus Ferry
Varies	Both	Park-and-ride prioritized	Golden Glades (TriRail) I-485/South Blvd (CATS) Eagleson (OC Transpo) Sammamish Park & Ride (Sound Transit)	Commuter Rail Light Rail BRT Commuter Bus
Varies	Access	Park-and-ride prioritized	El Monte Bus Station (LA Metro)	Commuter Bus
Entertainment, airport, and/or civic uses	Egress	Limited off-street parking available	Hartsfield Airport (MARTA) Hamburg Street (MTA) Airport Station (MBTA)	Heavy Rail Light Rail BRT
Varies	Egress	Some off-street parking	Great America (ACE)	Commuter Rail
Residential, retail, limited office	Both	Park-and-ride prioritized	Elgin (Metra) Port Townsend (WSDOT Ferry)	Commuter Rail Ferry
Varies	Access	Some off-street parking	St. Denis (MARC)	Commuter Rail



**Exhibit 4-4. Average station access mode share by station type.**

Station Type	Average Access Mode Percentage				
	Walk (%)	Bicycle (%)	Feeder Bus (%)	Auto (Drop-off) (%)	Auto (Park-and-Ride) (%)
Urban Commercial	82	1	10	2	5
High-Density Urban Neighborhood	72	2	14	4	10
Medium-Density Urban Neighborhood	80	1	9	4	7
Urban Neighborhood with Parking	35	3	21	10	31
Historic Transit Village	25	1	3	17	53
Suburban TOD	32	2	13	14	39
Suburban Village Center	30	2	16	12	40
Suburban Neighborhood	29	1	11	13	46
Suburban Freeway	10	1	12	12	65
Suburban Employment Center	29	3	25	9	36
Suburban Retail Center	30	2	19	11	39
Intermodal Transit Center	27	1	36	6	30
Special Event/Campus	55	2	24	6	13
Satellite City	7	6	12	16	59

Information was not available for some stations types, including busway, shuttle, and “legacy” rapid transit stations. These stations are individual by system and location: each has its own history and context.

### System-wide Station Access Modes

System-wide station access modes in Denver and Washington, D.C., are shown in Exhibit 4-5. Washington’s Metro, which has a larger service area and a stronger CBD than Denver, has a greater proportion of walking trips and a lower proportion of automobile trips. Buses accounted for about 20 percent of the boardings in both systems.

### Heavy Rail and Light Rail Access

Examples of heavy rail and light rail station types, boardings, and passenger arrival modes at individual stations are shown in Exhibit 4-6 and Exhibit 4-7 respectively. Key observations are:

- The station typology works in classifying stations. However, in some cases, additional classification appears desirable.
- At most stations, more than one mode serves a significant percentage of arriving passengers.

**Exhibit 4-5. Weekday station access modes in Denver and Washington, D.C.**

Access Mode	Denver LRT		WMATA(%)
	SW Corridor (%)	SE Corridor (%)	
Drove Alone	35	40	29
Carpooled	-	5	1
Dropped Off	5	5	9
Subtotal Auto	40	50	39
Bus	29	21	22
Walked	28	25	33
Bicycled	3	1	1
Other	0	3	5 <sup>a</sup>
Total	100%	100%	100%

<sup>a</sup> 4% commuter rail

Source: Denver RTD and WMATA

- The main access modes are walking, transit, and auto driving. Bicycles, where present, usually account for less than five percent of passenger arrivals.
- The highest numbers of boardings (and alightings) are in the CBD and some adjacent high-density areas. Pedestrian access dominates in the CBD, followed by transit.
- Transit and walking are the main means of arrival in cities and at other non-CBD stations serving high-density areas. However, where parking is provided, walking and automobile access can be greater than access by feeder transit. Stations at well-established commercial centers also rely on the three main access modes.
- Suburban stations rely mainly on park-and-ride access, followed by transit. While park-and-ride access dominates at multi-level garages, adjacent bus terminals can serve a quarter of all passenger arrivals.
- Urban and suburban transit centers can bring more passengers into stations than in areas of similar density without such facilities. Well-planned transfers are essential at these locations.
- Major BRT interchange facilities can account for half or more of all passenger arrivals.

### Commuter Rail Boarding

Data on selected access modes for six high-ridership Metra commuter rail stations in long-established Chicago suburbs were obtained. The average access mode percentages are shown in Exhibit 4-8.

Approximately 0.75 parking spaces were provided per boarding passenger at these stations.

### Automobile Access

The prevalence of auto access among various rapid transit stations is shown in Exhibit 4-9. The data for the New York area excludes the New York City subway system that relies mainly on pedestrian access.

Exhibit 4-10 shows arrival mode share at stations with major park-and-ride facilities along Boston's Red Line in 1984. Automobile access dominated, accounting for almost 60 percent of all boardings at these stations. However, there were still considerable proportions of pedestrian and bus access at most of the stations.

**Exhibit 4-6. Examples of station boardings and arrival modes (heavy rail rapid transit).**

City & System	Station	Type	Weekday Boardings	Percent by Arrival Mode (%)					
				Walk	Bicycle	Transit	Drive alone	Drop-off	Other
San Francisco (BART)	Montgomery St.	CBD	32,520	91	1	7	0	1	0
	Oakland City Center	CBD	13,380	92	1	4	0	1	0
	16th St. Mission	Urban Commercial	11,400	72	6	16	2	4	0
	Downtown Berkeley	Urban Commercial	11,930	84	5	7	2	2	0
	Walnut Creek	Suburban Neighborhood	6,040	24	2	13	47	14	0
Boston (MBTA): Blue Line	Wonderland	Suburban Neighborhood	4,350	10	0	17	65	8	0
	Beachmont	Urban Neighborhood with Parking	1,900	50	1	7	34	8	0
	Orient Heights	Urban Neighborhood with Parking	2,710	28	1	34	23	15	0
	Maverick	Medium-Density Urban Neighborhood	5,550	64	0	23	8	4	0
Boston (MBTA): Orange Line	Oak Grove	Suburban Neighborhood	4,970	31	2	22	26	19	0
	Sullivan Square	Intermodal Transit Center	6,070	28	0	53	16	3	0
	Downtown Crossing	CBD	3,410	88	0	14	2	2	0
	Chinatown	Special Urban	1,810	83	1	11	2	1	2
	Back Bay	Urban	3,140	45	0	53	0	0	2
	Massachusetts Ave	Urban-High Density	2,720	87	2	9	1	0	1
	Ruggles	Urban	4,410	54	0	42	4	0	0
	Stony Brook	Special Urban	2,380	94	0	0	3	3	0
	Forest Hills	Intermodal Transit Center	10,480	31	0	51	13	5	0
Boston (MBTA): Red Line	Alewife	Suburban Employment Center	7,570	27	6	24	36	7	0
	Harvard Square	High-Density Urban Neighborhood	10,210	49	1	48	2	1	0
	Central Square	Urban Commercial	7,860	84	1	12	3	1	0
	Downtown Crossing	CBD	-	86	0	13	0	0	1
	Andrew	High-Density Urban Neighborhood	3,670	66	1	23	6	4	0
	JFK/UMass	Special Event/Campus	4,280	51	0	37	7	5	0
	Quincy Center	Suburban Neighborhood	5,930	42	1	31	17	9	0
	Quincy Adams	Suburban Freeway	3,180	8	0	3	78	11	0
	Braintree	Suburban Terminal	3,040	13	0	9	52	25	0
	Ashmont	Urban Terminal	4,590	55	0	29	10	6	0

- Indicates data not available

Source: BART, MBTA

**Exhibit 4-7. Examples of station boardings and arrival modes (light rail transit).**

City & System	Station	Type	Weekday Boardings	Percent by Arrival Mode (%)					
				Walk	Bicycle	Transit	Drive alone	Drop-off	Other
New Jersey Transit	Trenton (3 Stations)	Urban/CBD	-	32	6	36	14	7	5
	Downtown Camden (4 Stations)	Urban/CBD	-	26	3	54	5	8	4
	Regional Park-and-Ride (3 Stations)	Suburban	-	4	0	4	77	13	2
	Town Center/Other (10 Stations)	Suburban	-	25	2	18	41	11	3
Portland, OR (TriMet)	Hatfield Government Center	Suburban Village Center	640	34	0	30	29	7	0
	Hillsboro Central TC	Suburban Village Center	900	58	0	27	7	8	0
	Willow Creek Transit Center	Intermodal Transit Center	780	18	0	41	36	5	0
	Beaverton Transit Center	Suburban Retail Center	3,860	58	0	25	8	9	0
	Pioneer Square South	Urban Commercial	11,490	86	0	13	1	0	0
	Old Town/ Chinatown	Urban Commercial	2,350	87	0	7	5	1	0
	Lloyd Center/NE 11th Ave	Urban Commercial	2,840	70	0	16	13	1	0
	Gateway/NE 99th Ave TC	Intermodal Transit Center	4,640	15	0	44	38	3	0
	E 162nd Ave	Medium-Density Urban Neighborhood	940	70	0	10	8	12	0
	Gresham Transit Center	Suburban Village Center	2,200	37	0	34	22	7	0
Portland Int'l Airport	Special Event/Campus	2,040	89	0	6	2	3	0	

- Indicates data not available

Source: NJ Transit, TriMet

**Exhibit 4-8. Commuter rail access mode percentages (Metra).**

Mode	Percentage of Arrivals (%)
Drive alone	47
Carpool	4
Dropped off	14
<i>Subtotal Auto</i>	<i>65</i>
Walk	22
Bus	11
Other	35

Source: Metra

**Exhibit 4-9. Prevalence of auto access among transit riders (percent of access).**

Urban Area	Population	Transit System	Transit Mode	Year	Auto			Total Auto Access
					Driver	Passenger	Drop-off	
New York – No. New Jersey, NY-NJ-CT-PA	21,200,000	LIRR, Metro North, NJT	CRR, ferry, express bus	1998	32%	8%		40%
Chicago, IL-IN-WI	9,160,000	Metra	CRR	1994	55	6	13	74
			CTA	HRT	1997	8.5	<0.7 <sup>a</sup>	3.0
San Francisco – Oakland – San Jose, CA	7,040,000	Caltrain	CRR	2001		40.3	12.8	53.1
			BART	HRT	1998	39	10	
Houston – Galveston, TX	4,670,000	Metro	Commuter bus (HOV)	1995	75.0	4.1		79.1
Pittsburgh, PA	2,360,000	PAT	LRT	1996-97	36.5	1.1	8.0	45.6
			Bus incl. busway	1996-97	7.7	0.2	2.9	10.8
Portland, OR-WA	2,260,000	Trimet	LRT	1997-98	25.9	1.1	6.1	33.1
Sacramento-Yolo, CA	1,800,000	RT	LRT	1996-97	22.5	0.5	5.1	28.1
Buffalo, NY	1,170,000	NFTA	LRT	1997-98	17.7	1.0	2.0	20.7

**Note:** <sup>a</sup> Percentage shown is for “other” mode of access, including auto passenger (in parked auto), thus the true auto passenger percentage is less. The corresponding total auto access percentage is necessarily approximated.

**Sources:** Adapted from *TCRP Report 95 (2, 4, 5, 6, 7, 8, 9, 10)*

**Exhibit 4-10. Arrival modes at selected Red Line stations (Boston).**

System	Walk	Bus	Park-and-Ride	Dropped Off	Other
Braintree Station	5%	10%	58%	27%	1%
Quincy Adams Station	6	3	80	10	<1
Quincy Center Station	24	41	21	13	0
Wollaston Station	44	2	40	15	0
North Quincy Station	33	4	52	10	1
All Five Stations	25	12	46	16	1

**Source:** Adapted from *TCRP Report 95 (2, 11)*

## Access Policy Guidelines

The above information regarding access mode share characteristics based on station typology and rapid transit service suggest several lessons for improving transit access. Transit agencies should establish station access policy guidelines both for upgrading existing stations and looking toward future system expansion. Several systems have already established such guidelines, including BART and WMATA.

The guidelines should apply to both new and existing stations. They should provide both arrival mode and transit station development policies, as population and employment characteristics in the ½- to 1-mile area around stations have an important bearing on passengers' choice of access mode.

- Transit agency policies often encourage low-cost, high-capacity access modes that produce the highest ridership and revenue benefits for the transit operator at the least cost.
- The number of people accessing a station by walking increases with increasing population density within a ½-mile radius. The presence of local retail and the absence of significant crime are also conducive to walking.
- Coordinating the bus routes and schedules of the various bus operators serving stations should be encouraged.
- Parking, while costly, remains essential. Parking charges can cover some or all parking operating costs, depending on demand and market factors.

Transit agencies should consider the following guidelines in establishing station access policy:

- All modes should be considered, as most stations will have at least some arrivals by each access mode.
- A station typology can be used to govern the arrival modes that should be encouraged or discouraged at particular types of stations.
- Access targets may be set for each station type to help guide decisions regarding appropriate access improvements. System-wide targets also may be established.
- It is more difficult to successfully develop park-and-ride in built-up areas. Small park-and-ride facilities around such stations should generally not be provided due to potential impacts of spillover parking on adjacent neighborhoods; however, provisions for passenger drop-off and pick-up could be desirable.
- Walking should be particularly encouraged as an access mode for stations in built-up areas. This outcome can best be achieved by increasing or intensifying the density of residential developments within a ½-mile radius of stations. Pedestrian access should be safe, convenient, pleasant, and direct. Sometimes it is possible to improve pedestrian access by buying a parcel or building a pedestrian bridge across barriers.
- Transit service standards for local (feeder) bus service should encourage clear, frequent, and direct routes. Fare policies should minimize costs to transfer between feeder buses and rapid transit.



## CHAPTER 5

# Travel Demand Considerations

Reliable estimates of travel demand both for a station as a whole and for the station's individual passenger access modes are important, but elusive challenges. The goal is to produce reasonable and reliable estimates that can be used to evaluate access planning options and to provide input to facility design.

Ridership demand can be estimated for three basic conditions, representing decreasing levels of existing knowledge: (1) existing stations, (2) new stations along an existing (or extended) rapid transit line, and (3) stations along an entirely new proposed line.

This chapter reviews current ridership estimating practice. It presents guidelines for estimating station ridership and access modes, including a ridership estimation model that was specifically developed for this research using data from many cities and over 450 individual stations.

The station access planning tool is available on the CD accompanying this report, and online at [www.trb.org/Main/Blurbs/166516.aspx](http://www.trb.org/Main/Blurbs/166516.aspx).

Appendix C provides further details about this tool, including instructions for its use. Appendix B and the literature review developed for this research study (*TCRP Web-Only Document 44: Literature Review for Providing Access to Public Transportation Stations*) provide additional detail on existing evaluation tools and demand modeling techniques.

### Review of Practice

Travel demand models are a familiar tool for estimating transit ridership and have been used for decades to predict transit ridership for rapid transit services, especially large capital projects. Appendix B provides a detailed summary of the current state of travel demand modeling with respect to transit access. Nearly all MPOs have demand models available, and most of these models provide at least some level of ability to estimate transit use. Thus, most transit agencies have access to at least some travel demand model without the need to develop in-house expertise in building and calibrating demand models

However, many existing demand models lack the sensitivity needed to adequately assess the impacts of specific transit station access alternatives. *TRB Special Report 288: Metropolitan Travel Forecasting: Current Practice and Future Direction* evaluated the ability of current travel demand models to meet a broad set of needs, including modeling transit demand. This report noted several issues with current travel demand models that impede their ability to accurately assess transit access modes.

As detailed in Appendix B and *TCRP Web-Only Document 44: Literature Review for Providing Access to Public Transportation Stations*, this research effort conducted a detailed review of published

literature on transit access demand. This review suggests several specific factors that appear highly correlated with access decisions and will likely be important in any transit access model:

- Parking cost and supply;
- Quantity and quality of feeder transit service;
- Type and diversity of land uses;
- Residential and employment density;
- Quality and continuity of pedestrian facilities;
- Station area demographics;
- Safety;
- Auto ownership; and
- Travel time.

Factors that are positively correlated with auto access include parking supply and auto ownership, while factors positively correlated with walking access include density and land use mix. No one model incorporates all of the factors listed above and some are used as proxies for other factors. For example, higher densities and a mix of uses tend to be correlated with higher quality pedestrian infrastructure.

Several studies also emphasize the importance of concentrating residential development within a ½-mile radius of a rapid transit station.

- Residents who live within a 5-minute walk of transit stations are 2.7 times more likely to commute by rail (12).
- Most pedestrians are willing to walk up to ½ mile to access stations. For each additional 0.3 mile of walking distance, the probability of walking drops 50 percent. Density, local retail, and absence of major arterials near the station are the most important factors influencing walk trips to BART, together with individual characteristics such as gender and availability of a car (13).
- WMATA (Washington, D.C.) finds that the likelihood of riding rail transit declines as the distances to both residential and non-residential developments near stations increase. A zone study indicated the access percentages shown in Exhibit 5-1. Exhibit 5-2 shows how the percent of riders using transit in Toronto, Edmonton, Washington, D.C., and San Francisco declines as distance from the rail station increases.
- With regard to bicycle access, the international literature review shows that it is possible for bicycles to comprise up to 40 percent of transit access trips. However, realizing such a high percentage is largely dependent on factors outside transit agency control, as system-wide quality of bicycle facilities, topography, weather, and bicycle culture all play large roles in people's willingness to bike. Even so, research indicates that provision of bicycle facilities at transit stations, in particular high-quality bike parking, does have a significant impact on bicycle access.

#### Exhibit 5-1. Development distance related Metro rail ridership (2002).

Distance	Percent Using Rail	
	Office (%)	Residential (%)
At Station	35	54
¼-mile	23	43
½-mile	10	31

Source: Adapted from *TCRP Report 95 (14, 15)*



**Exhibit 5-2. Work trip rail mode share by distance from residential sites to station.**

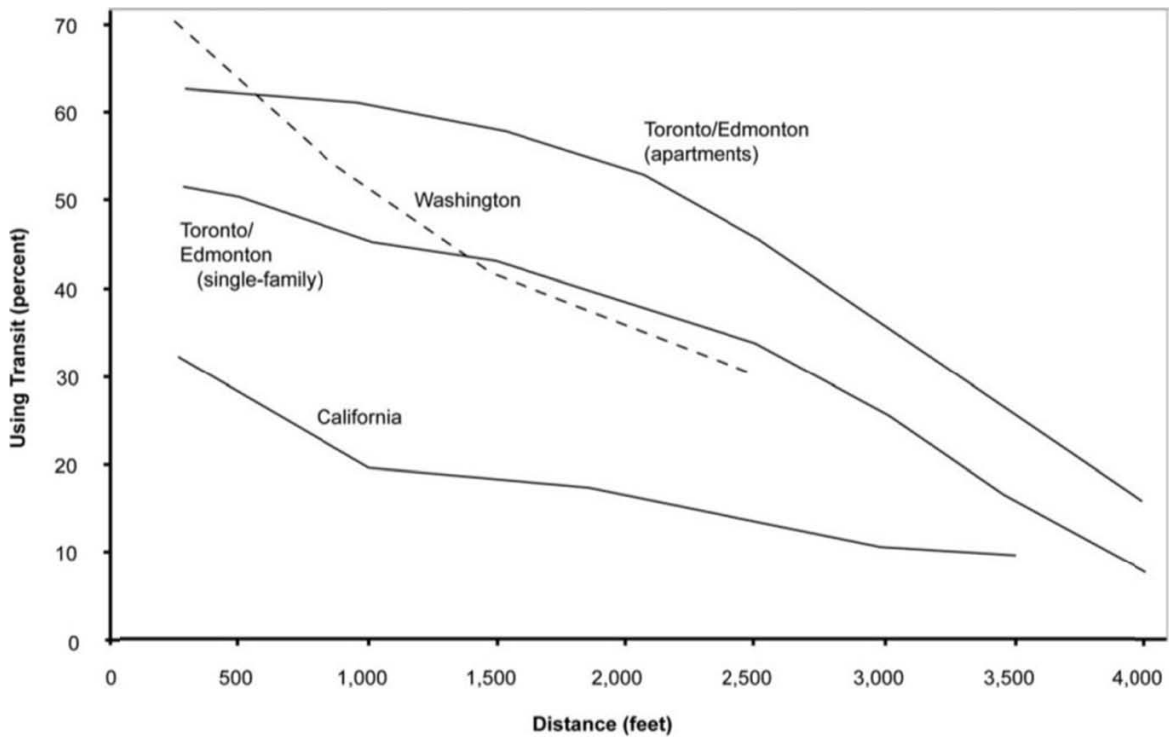

Source: TCRP Report 95 (12, 14)

- The research shows that there are many factors other than distance that affect the decision on whether to walk, including urban design, pedestrian facilities, crime, and individual characteristics. By considering these factors, agencies have the potential to increase walking mode share to stations.

### Station Access Model

A station access model was developed based on land use and ridership information assembled from public transport systems across the United States, including heavy rail and commuter systems serving strong downtown areas (New Jersey Transit, New York Metro-North, Washington, D.C., Boston, and San Francisco) as well as light rail systems in smaller cities (Denver and Portland). In total, data for over 450 stations were used in development of the station access tool. The planning model can be accessed on the accompanying CD or downloaded from [www.trb.org/Main/Blurbs/166516.aspx](http://www.trb.org/Main/Blurbs/166516.aspx).

Exhibit 5-3 gives the linear regression ridership models (equations) for estimating station ridership for each of the auto, bicycle, walking, and transit access modes. These equations can help quantify the likely ridership at new stations along an existing line or future growth at existing stations.

The table also gives the relevant input variables used for each mode, linear regression coefficients, and statistical measures-of-fit. Note that the presence of heavy rail public transport acts essentially as a surrogate for CBD employment.

In general, Exhibit 5-3 shows relatively high R-squared coefficients (greater than 0.7) for each of the access modes with the exception of feeder bus service. This is likely the result of a lack of data

**Exhibit 5-3. Station ridership estimation model.**

	Coefficient	t	Significance
<b>Auto Ridership Model</b> (R <sup>2</sup> = 0.821)			
Constant	133.597	2.290	.023
Heavy rail dummy variable <sup>a</sup>	782.449	13.319	.000
Car parking spaces	1.282	35.452	.000
Percent zero-car households	-347.494	-1.900	.058
<b>Bicycle Ridership Model</b> (R <sup>2</sup> = 0.771)			
Constant	-102.015	-6.594	.000
Jobs within ½ mile	-0.001	-.864	.389
Population within ½ mile	0.008	4.446	.000
Bicycle parking spaces	1.032	6.980	.000
Bicycle commute mode share	3,241.579	5.730	.000
Percent zero-car households within ½ mile	249.852	3.164	.002
<b>Walk Ridership Model</b> (R <sup>2</sup> = 0.717)			
Constant	-456.090	-3.665	.000
Heavy rail dummy variable <sup>a</sup>	1,444.994	8.069	.000
Jobs within ½ mile	0.015	1.598	.111
Workers within ½ mile	0.481	5.370	.000
Workers who walked to work within ½ mile	2.390	8.639	.000
<b>Feeder Transit Ridership Model</b> (R <sup>2</sup> = 0.373)			
Constant	-261.387	-1.733	.084
Heavy rail dummy variable <sup>a</sup>	520.732	4.868	.000
Connecting transit lines	62.799	9.687	.000
Workers within ½-mile	.019	1.554	.121
Parking utilization at station	211.484	1.661	.098

<sup>a</sup> Heavy rail = 1; other = 0

collected on available feeder transit due to limited resources and lack of a centralized data source. Only the total number of routes serving a given station was collected, meaning that information on the overall quality of the service at a given station (e.g., reliability, frequency, service coverage) was unavailable for incorporation into the modeling.

The results of the modeling effort are consistent with the literature review findings: population density, employment density, and available parking are the most important factors determining station access decisions. Additional notes on each of the modal models include:

- *Automobile*—As expected, the number of available parking spaces was the primary determinant of auto access. The percentage of zero-car households was also found to be significant, with auto access to transit decreasing in areas with lower auto ownership.
- *Bicycle*—Bicycle access to transit increased in areas with higher population density and also those with lower auto ownership. Bike access was also higher in areas where more people travel by bike in general (measured by bicycle commute mode share) indicating the overall

bicycle-friendliness of an area contributes to bicycle access. The number of bicycle parking spaces available was positively correlated with bicycle access but this may not reflect a causal relationship, as agencies may be more likely to concentrate bicycle parking in areas with the highest underlying demand.

- *Pedestrian*—Both employment density and population density are positively correlated with increased pedestrian access trips. Note that worker density (i.e., the number of employed residents) was found to be more strongly associated with pedestrian than simple population density. In addition, walk access to transit was higher in places where pedestrian travel is more common (measured by walking commuters), indicating the overall pedestrian-friendliness of an area contributes to pedestrian access.
- *Feeder Transit*—The number of available transit connections is strongly associated with more feeder transit access trips, as expected. Feeder transit access is also higher in areas of higher population density (which are likely to support higher frequency feeder service) and at stations with higher parking utilization (indicating that passengers may be more likely to switch to feeder transit if parking is difficult to obtain).

## Effects of Improved Station Access

There are many situations where it is desirable to improve access to an existing station. In these cases, quantified estimates of usage, benefits, and costs should be developed. Relevant information relating to existing station usage includes station boardings by time of day, modes of travel used by boarding and alighting passengers, and off-street parking accumulations by time of day. Information on bus routes, frequencies, and passenger loads should also be assembled. Transit agencies often periodically collect this information, but when the information is not already available, field studies should be conducted. Past trends in station boardings and access modes should be analyzed. These can provide a basis for estimating likely future trends. Obtaining population, worker, demographic and car ownership trends in a ½-mile (or sometimes 1-mile) radius of the station will prove useful.

## Park-and-Ride

Many park-and-ride facilities operate near, at, or beyond their capacities. This excess demand can result in spillover parking impacts to surrounding neighborhoods and also inhibits ridership. Where a station's park-and-ride facilities operate at or near capacity (i.e., over 90 percent occupancy), providing more spaces will likely increase ridership. This has been the experience of both BART and Metro-North.

Exhibit 5-4 summarizes Metro-North's experience in Connecticut. The net daily boarding increase at the origin station per parking space added was 0.11 in New Haven, 0.60 in South Norwalk, and 0.92 in Bridgeport. The exhibit suggests that up to one new rider can be gained per parking space added. Of course, demand for parking is always finite, suggesting that agencies should conduct a more thorough demand analysis in situations where parking is being expanded significantly (e.g., an increase of more than 25 percent).

Some communities along Metro-North commuter lines manage parking. Often there are waiting lists for reserved parking spaces. In similar situations, some or all of these parkers should be added to the observed parking utilization for the purposes of demand estimation.

Pricing parking spaces provides an important means of recovering some of the initial development costs and/or ongoing operating costs of the parking. However, charging for parking may also reduce demand for parking and thus ridership. BART's experience has been that pricing

**Exhibit 5-4. Changes in parking supply and demand at three Connecticut stations.**

	<b>New Haven</b>	<b>South Norwalk</b>	<b>Bridgeport</b>
Time Period Studied	1985-1999	1996-1999	1985-1999
Parking Spaces Added	+628	+325	+500
Additional Rail Ridership			
Gross Ridership Increase	+467	+250	+736
Ordinary Growth (estimated 1.5% / year)	+400	+55	+277
Ridership Increase Attributed to Mode Shifts Induced by Parking ("New Riders")	+67	+195	+459
Additional Rail Ridership per Parking Space Added			
Gross Ridership Increase / Space Added	0.74	0.77	1.47
"New Riders" / Space Added	0.11	0.60	0.92

Note: External factors affecting Bridgeport included lowered train fares, free parking at state lot, and station area improvements.

Source: *TCRP Report 95 (14, 16)*

parking has not reduced parking usage or rapid transit ridership; however, CBD parking costs are relatively high in BART's service area. In general, park-and-ride demand is less likely to be replaced when the CBD all-day parking charge is less than the round trip rapid transit fare plus the daily parking charges at the station.

The effects of changing park-and-ride supply and pricing at BART stations are shown in Exhibit 5-5. The various demand elasticities (shrinkage factors) shown in the exhibit provide a basis for estimating the likely effects of changing parking supply and bus service. Note that when parking is not fully utilized, pricing shows an elasticity of  $-0.33$  (i.e., demand is reduced).

Where spaces are fully occupied, removing spaces would either increase parking spillover in areas adjacent to the station or would reduce auto access trips and rapid transit ridership.

**Exhibit 5-5. BART elasticities and defaults (shrinkage factors).**

<b>A. ELASTICITIES</b>		
1.	Parking space is 90% utilized	
	• Parking pricing	no effect
2.	Parking space is less than 90% utilized	
	• Parking pricing	-0.33
3.	Feeder bus service hours	+0.60
<b>B. PERCENTAGE SHIFTS</b>		
1.	Auto to Bus when Feeder Bus Service is increased	2%
2.	Shift from auto to other when parking is removed (parking 90% or more utilized)	34%
3.	Bus to auto when parking is added (parking 90% or more utilized)	34%

Source: BART

## Transit Service Changes

Changes in feeder bus revenue miles, travel times, frequencies, and fares will also influence ridership. Elasticity factors are commonly used to quantify these changes. Ridership elasticity is defined as the change in ridership corresponding to a 1 percent change in bus fares, revenue miles, travel times, or service frequency.

### Elasticity Methods

Three types of methods can be used to compute elasticity: (1) shrinkage factors, (2) midpoint linear arc elasticity and (3) log arc elasticity:

1. **Shrinkage Factor.** The shrinkage factor has been used as a “rule of thumb” for many years to estimate the ridership effects of fare changes. It is the simplest method to apply and gives a reasonable approximation for small fare changes. The percentage increase in ridership is equal to the percentage change in an attribute (e.g., fare) times the appropriate elasticity factor. The equations are as follows:

$$R_2 = R_1 + \frac{ER_1(X_2 - X_1)}{X_1}$$

where:

$E$  = elasticity

$R_1$  = base ridership

$R_2$  = estimated future ridership

$X_1$  = quantity of base attribute (such as travel time or frequency)

$X_2$  = quantity of future attribute

2. **Midpoint (Linear) Arc Elasticity.** This method is commonly used in estimating ridership changes and is the method used in Chapter 5. It is defined as follows:

$$R_2 = \frac{(E-1)X_1R_1 - (E+1)X_2R_1}{(E-1)X_2 - (E+1)X_1} = R_1F$$

where:

$E$  = elasticity

$R_1$  = base ridership

$R_2$  = estimated future ridership

$X_1$  = quantity of base attribute (such as travel time or frequency)

$X_2$  = quantity of future attribute

$F$  = multiplier

3. **Log Arc Elasticity.** Log arc elasticities are another method of calculating elasticities, but has seen relatively few transit applications. As such, the formulas are not reproduced here.

A comparison of three elasticity computation methods is shown in Exhibit 5-6. For small changes ( $\pm 10$  percent), the three methods give similar results. However, for large changes, results obtained from the shrinkage factor diverge considerably from the other two methods. Therefore, users of these methods should always be aware of the method originally used to develop the elasticity factor and should use the corresponding calculation method when applying the factor.

### Applications

The application of elasticity factors is straightforward. Typical midpoint elasticities (Method 2) are shown in Exhibit 5-7. Where a transit agency has produced specific elasticity values, these should be used instead.

**Exhibit 5-6. Elasticity values for different methods of computation.**

Fare Change (%)	Log Arc Elasticity	Midpoint Arc Elasticity	Shrinkage Factor
-50	-0.300	-0.311	-0.46
-30	-0.300	-0.303	-0.38
-10	-0.300	-0.300	-0.32
+10	-0.300	-0.300	-0.28
+30	-0.300	-0.302	-0.25
+50	-0.300	-0.311	-0.23
+100	-0.300	-0.311	-0.19

Source: Calculated

**Exhibit 5-7. Typical midpoint arc elasticities.**

Item	Travel Time	Bus Miles	Bus Frequencies
Application	New routes replace or complement existing routes	Service expansion	Greater frequency of existing routes
Range	-0.3 to -0.5	0.6 to 1.0	0.3 to 0.5
Typical	-0.4	0.7 to 0.8	0.4

Source: TCRP Report 99 (18)

Assume that travel times to the rapid transit station decrease from 12 to 10 minutes as a result of a service improvement to feeder transit service. The following changes in ridership are anticipated based on an elasticity of  $-0.35$  and a base ridership of 1,000.

By the shrinkage factor method:

$$R_2 = 1,000 + \frac{(-0.35)(1,000)(10-12)}{12} = 1,058 = 5.8\%$$

By the midpoint arc elasticity method:

$$R_2 = \frac{(-0.35-1)(12)(1,000) - (-0.35+1)(10)(1,000)}{(-0.35-1)(10) - (-0.35+1)(12)} = 1,066 = +6.6\%$$

## Estimating Ridership for New and Infill Stations

Estimating ridership for new stations as well as infill stations is normally done for future planning or horizon years. The process requires knowledge of existing travel patterns and reasonable estimates of future population, employment, and land development.

Estimates can be made either by using this report's station ridership model and access planning tool (or an agency-specific model) or using a traditional four-step model using trip generation, trip distribution, modal allocation, and trip assignment to transit and highway networks. When a four-step model is used, the model should be calibrated for both the transit and automobile

modes, and the model's network design should include highway and transit links and a means to model multi-modal trips, such as park-and-ride.

The modal allocation of travel is a major concern in rapid transit demand estimation. Most regional planning agencies use a logit model to estimate mode splits. Logit models assume that the share of trips by a specific mode is a function of the mode's utility (i.e., attractiveness to passengers, based on various user and system characteristics such as vehicle ownership, travel time, and price) divided by the sum of the utilities of all possible modes for the trip.

### Ratio Method for Infill Stations

In addition to the methods described, a simple ratio method may also prove to be a valuable tool in estimating demand for infill stations. This method works by assuming that the proposed station will have similar relation of ridership to surrounding land uses. To apply this method, information should be assembled on the population, demographic, and development characteristics for an area within ½ to 1 mile of the proposed station and the two adjacent stations. Exhibit 5-8 summarizes the information that should be assembled.

Basic information should be compared for the proposed station and the two existing adjacent stations. These key comparisons include total population, resident workers, and employment in the station areas. The catchment area characteristics of the proposed station should be compared with those of the two adjacent stations. The ratios of ridership to the key demographic factors (i.e., population, workers, and employment) can be determined for the two existing stations and then applied at the proposed station to estimate number of boardings.

Exhibit 5-9 provides an illustrative example. The new station ridership can be expressed as either a range or as average. The analysis may also be extended to also estimate mode split and parking demand.

#### Exhibit 5-8. Desired station profile information within ½-mile radius of existing and proposed stations.

Station Characteristics	Station Area Demographics
Status	Population
Rapid transit mode	Workers
Station type	Jobs
Predominant Land Use	Median household income
Topography	Percent zero-car households
	Vehicles per worker
<b>Access Provisions</b>	
Daily parking spaces (at the station)	
Reserved parking spaces	
Daily and monthly parking rates	
Parking occupancy at 9 am	
Bicycle parking spaces	
Round trip transit fares	
Connecting transit lines	
Transfer charge (if any)	

**Exhibit 5-9. Illustrative computations for estimating boardings at a proposed station.**

	<b>Existing Station A</b>	<b>Proposed Station</b>	<b>Ratio</b>
Boardings	4,000 boardings	X	
Population	10,000 population	8,000	0.80
Employment	6,000 workers	5,000	0.83
			$x \approx 0.80 * 4,000 = 3,200$
			$x \approx 0.83 * 4,000 = 3,320$
	<b>Existing Station B</b>		
Boardings	6,000 boardings	X	
Population	16,000 population	8,000	0.50
Employment	9,000 workers	5,000	0.56
			$x \approx 0.50 * 6,000 = 3,000$
			$x \approx 0.56 * 6,000 = 3,360$

Exhibit 5-9 shows that the proposed station could have daily boardings of between approximately 3,000 and 3,400. This ratio or interpolation method requires that the land uses at the proposed stations are similar to those at adjacent stations. When this is not the case, the characteristics for the planned station should be compared with those for stations elsewhere in the system with similar uses.

Note that this method assumes all of the ridership at the infill station consists of new riders. In practice, this is unlikely to be true, and analysis of infill stations should consider the potential that an infill station will simply re-distribute existing ridership rather than generate new riders.





## CHAPTER 6

# General Station Access Guidelines

Station access improvements should reflect the needs and opportunities of individual stations, as identified through the planning process. These improvements will depend on where each station is located and its relation to pedestrian, bicycle, feeder transit, and automobile access. Land availability, costs, and uses; future development plans; and community attitudes will influence the location and type of specific improvements.

Transit station designs should attempt to accommodate and coordinate all access modes wherever possible, and some level of pedestrian access always should be provided, even for the most auto-oriented stations. However, the appropriate mix of access services should each reflect local context (e.g., densities, development patterns, street systems, and connecting transit services).

This chapter and the chapters that follow contain guidelines for providing access to stations. The guidelines present best practices for improving multi-modal access and providing seamless connections for passengers. They are based on a literature review, research team observations, and synthesis of access guidelines for BART, WMATA, and RTD (Denver).

Trade-offs are usually necessary to balance competing objectives. They are especially important where new stations are planned and are also useful where existing station access is being upgraded. Trade-offs can include strategic choices (e.g., providing TOD in place of a parking lot) or they can include fiscal alternatives, such as alternative funding strategies for additional feeder transit service. The eight-step planning process outlined in Chapter 2 provides a framework for appropriately considering these trade-offs.

Where trade-offs are required, agencies should use locally developed guiding principles (e.g., access mode hierarchy and evaluation criteria) to select actions. Moreover, achieving many best practices will require collaboration with local jurisdictions to make access improvements to the local transportation network. The station access spreadsheet tool (in Appendix C) provides a way to quantify station access improvements.

### **Background**

Rapid transit has played an important role in the development of urban areas for more than a century, especially around stations. Stations along both legacy and new lines have benefited from the travel time savings, frequent service, and reliability.

### **Legacy Rail Transit Service**

“Legacy” rail transit services were built to improve access to city centers, better serve built-up areas, and stimulate land development in outlying areas. They usually resulted in increased development both in the CBD—the prime example of TOD—and in outlying areas.

Rapid transit service built before the mid 1920s was expected to stimulate land development that would generate population growth and new transit ridership. An explosion of automobile ownership and the collateral effects of the Great Depression ended this approach (19).

The legacy lines mainly ran over, under, or adjacent to major streets, and penetrated the communities they traversed. They were characterized by close station spacing and reliance on walk-in patrons and perhaps bus (or streetcar) riders who sometimes were required to pay an additional fare. Multiple-track operation in New York City, Chicago, and Philadelphia enabled both express and local service. At major junctions with cross-town local transit routes, large commercial centers sometimes emerged. Examples include 149th Street and Fordham Road in the Bronx; Flushing and Jamaica in Queens; Uptown and Englewood in Chicago; Davis Street in Evanston, Illinois; and Central and Harvard Squares in Cambridge, Massachusetts.

### **Post-World War II Lines**

Newer rapid transit service (built since World War II) extended farther out into lower-density residential areas. Often located along railroad or freeway rights-of-way, these lines had wider station spacing. Stations relied largely on bus and park-and-ride access and some of the transit agencies (e.g., MBTA) became the largest parking operators in their regions.

There was less synergy between the transit service and the surrounding land development in many corridors. Creating TODs often depended upon public intervention (e.g., zoning and other incentives), as well as strong market forces. Still, where public policies were supportive and market forces were strong, TOD became a reality.

### **Commuter Rail Lines**

From the beginning, commuter rail service relied on both pedestrian and private vehicle access. During the last several decades, major expansions of park-and-ride facilities occurred along commuter rail lines, especially at outlying locations. Land development impacts have varied widely, depending upon station location and age.

Commuter rail serves established cities and growing suburbs. Stations in places like Stamford, Connecticut, Providence, Rhode Island, Newark, New Jersey, and White Plains, New York, have become major development nodes. Intermediate stations usually have neighborhood commercial and institutional development. New suburban and exurban stations, often surrounded by vast parking lots, usually have little TOD, but there are exceptions.

### **Bus Rapid Transit (BRT)**

Increasing demand for high-quality rapid transit service coupled with the relatively low development cost has led many communities to build BRT lines instead of traditional rail transit. BRT also offers greater operating flexibility. Ottawa found that a BRT system could be built for half the cost of rail transit, and that it would cost 20 percent less to operate. Boston selected BRT for the Silver Line due to its operational cost and service benefits.

Land development benefits associated with full-featured BRT may be similar to those found along rail transit lines, although data on TOD surrounding BRT is limited. Ottawa and Pittsburgh experienced significant capital investment in properties near its BRT stations, and property values along Brisbane, Australia's, busway grew by 20 percent following its construction (20).

## Station Access Objectives

The following broad objectives underlie rapid transit station access:

- Provide convenient, safe, and secure access for all station users.
- Make transfers easy, attractive, and seamless.
- Recognize that pedestrian access is the basis for all aspects of station access design.
- Reflect the needs of all users, including the elderly and persons with disabilities.
- Optimize each mode's access to the station.
- Develop access designs that encourage and reinforce transit ridership.
- Design access that is acceptable to users, transit and highway agencies, and surrounding communities.

To the maximum extent practical, access designs should connect stations with their surrounding communities. Sometimes this integration can be achieved through good urban design or TOD.

Station access priorities depend on each station's location, history, setting, land uses, and density. Station access plans should generally consider, at a minimum:

1. Pedestrians and bicyclists,
2. Bus riders,
3. Auto passenger drop-off and pick-up,
4. Short-term parking, and
5. Long-term parking.

Access designs should reflect established transit and highway best practices and standards. These include *TCRP Report 10: Transit Capacity and Quality of Service Manual*, AASHTO's "Green Book" and park-and-ride and pedestrian guides, the *Manual on Uniform Traffic Control Devices*, state-developed design manuals, and transit agency design and operating standards.

## Additional Considerations

Several overriding considerations are important in planning for access to public transit stations. These include nontraditional auto access and travel patterns. Planners should be aware of the following and consider how they may affect station access decisions.

**Reverse commutes** and **nontraditional commute patterns** create both a challenge and opportunity for transit agencies. Reverse commuters require access provisions at stations where the majority of passengers are egressing, and vice versa. Accessing passengers may compete for space in the areas immediately surrounding the platforms. Provisions should be made, however, as they use reverse-direction service that is often under-utilized. In fact, where permitted, some reverse commute riders use suburban park-and-ride lots to store their vehicles while they are home, using them to travel between the station and their work. This can be complementary with traditional commute patterns if the timing is right.

**Car sharing** and **bike sharing** are emerging to expand the reach of transit. In suburban locations where land uses and transit service are not as dense, riders can use car sharing and bike sharing to reach destinations beyond walking distance from the station. Agencies should consider provisions for car and bike sharing services, with preferential placement near the station.

**Carpooling** and **vanpooling** to stations is also growing in popularity, particularly where parking is priced and/or limited in supply. In fact, some communities have seen the emergence of casual carpools, in which drivers pick-up passengers at designated locations and take them

to stations. Access for these users should be prioritized above other auto access, as they provide more boardings per vehicle storage area. Likewise, dial-a-ride or paratransit service connects mobility-impaired riders to the rapid transit service. Connections for these vehicles must be ADA-accessible.

Lastly, design considerations should emphasize flexibility where needed. Design guidelines are often intended for areas with few space limitations. However, many transit stations are confined by existing infrastructure and development, and it may be appropriate to allow design exceptions that result in considerably improved overall station access.

## Overview of Options

Station access improvements are usually provided on the approaches to stations, in the areas adjacent to stations, and between the station entrances and station platforms. Exhibit 6-1 shows some improvement opportunities pertaining to areas on station approaches and adjacent to stations. Opportunities at the immediate approaches to the station are identified under “Approach,” and those in the larger station area under “Environs.” Subsequent chapters provide additional detail for each access mode.

**Exhibit 6-1. Station access improvement opportunities by access mode.**

Type of Improvement		Approach	Environs
<b>1. Pedestrians and Bicyclists</b>			
1-1.	Provide paved sidewalks at least 5 feet wide	✓	✓
1-2.	Remove sidewalk clutter near station entrances		✓
1-3.	Provide station entrances through the buildings		✓
1-4.	Build pedestrian overpasses and/or underpasses		✓
1-5.	Provide weather-protected connections to adjacent land use		✓
1-6.	Install traffic signals at busy junctions	✓	✓
1-7.	Improve night visibility	✓	✓
1-8.	Install intersection safety improvements (e.g., crosswalks)	✓	
1-9.	Install wayfinding on approaches to station	✓	
1-10.	Install bicycle lanes	✓	
1-11.	Provide bicycle paths		✓
1-12.	Provide secure bicycle storage at stations	✓	
<b>2. Bus</b>			
2-1.	Provide free or low-cost transfers		✓
2-2.	Provide bus transfer opportunities in enclosed areas		✓
2-3.	Improve service frequencies	✓	
2-4.	Establish limited-stop bus service	✓	
2-5.	Establish new bus routes to serve station	✓	✓
2-6.	Reroute existing bus routes to serve station	✓	✓
2-7.	Locate bus stops near station entrance		✓
2-8.	Break bus routes to better serve station	✓	✓
2-9.	Separate station bus access from automobile access		✓
2-10.	Establish off-street bus terminal		✓
2-11.	Provide off-vehicle fare collection at station		✓
2-12.	Provide additional lane for bus stops on cross street at station		✓
2-13.	Prohibit rush period parking along bus route	✓	
2-14.	Install transit signal priority at signalized intersections	✓	
2-15.	Install curb or interior bus lanes	✓	
2-16.	Install bus bays or bus bulbs along approach roads	✓	
2-17.	Build “bus bridge” over freeway with rapid transit in median	✓	
2-18.	Provide bus storage area	✓	✓

(continued on next page)

**Exhibit 6-1. (Continued).**

Type of Improvement		Approach	Environs
<b>3. Automobiles (including park-and-ride and kiss-and-ride)</b>			
3-1.	Provide passenger drop-off (kiss-and-ride) at stations		✓
3-2.	Build park-and-ride facility (lot or garage) at station		✓
3-3.	Separate access facilities for park-and-ride and for transit		✓
3-4.	Price park-and-ride low relative to transit and CBD parking costs		✓
3-5.	Provide direct pedestrian access from parking to station		✓
3-6.	Arrange parking facility to minimize walking distances		✓
3-7.	Minimize conflicts on pedestrian access routes (where possible)	✓	
3-8.	Expand park-and-ride facility (add spaces)		✓
3-9.	Provide direct freeway access to parking facilities	✓	
3-10.	Provide separate bus storage area		✓
3-11.	Provide short-term parking areas and price accordingly	✓	
3-12.	Improve traffic operations on roads serving park-and-rides	✓	
3-13.	Construct new access route	✓	✓
3-14.	Integrate park-and-ride with transit-supportive development		✓
3-15.	Provide taxi/limousine loading area		✓
3-16.	Install a one-way street couplet	✓	
3-17.	Eliminate peak or all-day parking	✓	
3-18.	Add intersection capacity	✓	

The public agencies that plan, design, and implement possible improvements depend upon the type of improvement and interagency working arrangements. Sometimes several agencies share responsibility for specific improvements. Close working arrangements between transit and roadway agencies are essential.

### Sequence of Access Design Chapters

The chapters that follow are:

Chapter 7 Pedestrian Access to Transit

Chapter 8 Bicycle Access to Transit

Chapter 9 Transit Access

Chapter 10 Automobile Access and Park-and-Ride

Chapter 11 TOD and Station Access

# Pedestrian Access to Transit

This chapter outlines planning and design principles to enhance pedestrian access to high-capacity transit stations. Providing safe and accessible pedestrian access to and through transit stations is important for several reasons, even at stations with extensive park-and-ride facilities. Walking has no environmental impacts, and accommodating pedestrians at stations is considerably less expensive than providing parking or feeder transit services. Encouraging walking also promotes social equity, as walking is associated with no additional costs to passengers and is available even to those riders without access to private vehicles or feeder transit service. Finally, even at stations where pedestrian access is low, some patrons will choose to walk. Thus, some level of pedestrian access should always be provided, even for the most auto-oriented stations, to ensure safe access for transit patrons.

## Context

Historically, walking (as well as feeder transit in the form of surface-running streetcars) was the primary means of accessing transit stations, and most transit systems built before World War II continue to rely heavily on pedestrian access for ridership. More recently, the development of transit systems in lower-density areas—often parallel to freeways, with large park-and-ride facilities—has increased the importance of auto and feeder transit access relative to walking in many newer systems.

While this pattern fits generally, detailed examination indicates that the extent of pedestrian access depends primarily on station characteristics and adjacent land uses (i.e., station typology and the connectivity and character of the street network) rather than on the age of the transit system or age of surrounding development. For example, WMATA's heavy rail system, constructed entirely since 1970, exhibits widely differing pedestrian access patterns between stations. Suburban stations in low-density areas (e.g., Greenbelt, West Falls Church) have fewer than 10 percent of passengers arrive as pedestrians, whereas pedestrian access accounts for over 70 percent of access at many urban stations in the District of Columbia and Arlington County. Similarly, TriMet has achieved a system-wide pedestrian access mode share of over 50 percent at non-CBD stations through focusing new rail lines in areas with existing or planned pedestrian-friendly development.

These examples suggest that transit agencies (and partner transportation agencies) may be able to influence the number of pedestrian access trips to some degree, as well as the quality and safety of those trips. This is particularly true in the development of new stations, where there may be several options for station location and pedestrian connections to adjacent land use. At existing stations, pedestrian access can be enhanced by the addition of sidewalks (if not present), crossings, curb ramps, and other improvements to increase safety and accessibility.

Improved pedestrian facilities at some existing stations may have the potential to substantially increase pedestrian access. For example, a study of the El Monte bus station in Los Angeles showed that nearly 13,000 people live within 1 km (0.6 miles) of the station, but less than 1,000 have a feasible walking path to it due to connectivity barriers. As a result, the pedestrian mode share is only 4 percent, far below what the research indicates it should be. The author further estimated that moderate improvements to the pedestrian pathways could increase the walk-in population by as much as eight-fold (31).

## Interagency Coordination

As described in Chapters 2 and 6, interagency coordination is essential to achieve improved transit access; this is also true for pedestrian access, as the responsibility for providing sidewalks, traffic signals, crosswalks, and other pedestrian improvements on roadways approaching the station usually falls on the local jurisdiction or state DOT rather than the transit agency (which is typically responsible only for the land it owns). As a result, transit agencies may not be able to achieve many of the design principles listed below without coordination with roadway agencies.

One example of interagency coordination is Denver's RTD, which works with numerous local jurisdictions to improve pedestrian access to stations. One purpose of its 2009 Access Guidelines is to provide guidance to local jurisdictions for station area improvements to ensure a consistent approach system-wide. While RTD places pedestrian access at the top of its access hierarchy, working to implement pedestrian improvements located outside of RTD property can be a challenge. While local jurisdictions may ask RTD to pay for these improvements, RTD will typically only fund improvements located on its property. TOD policies and processes are an exception to this general rule, where the agency's ridership needs are satisfied through employment, retail, and housing development near its stations.

New York City's Safe Routes to Transit program is another example of how a local government program can directly affect transit access. New York City Transit street supervisors help identify missing sidewalks for that element of the program, as part of a larger effort to create collaboration between the city government and transit agency. Buses that are more accessible offer a higher level of service to subway stations as well.

## Factors Affecting Pedestrian Access

The primary factor affecting pedestrian access is distance. In general, stations with higher-density land uses in the surrounding area (i.e., more destinations within walking distance of the station) will have higher pedestrian access. This is both intuitive and documented through numerous data collection and modeling efforts. Traditionally, ½ mile has been assumed as the reasonable maximum walking distance for pedestrian access to high-capacity transit, in which those passengers located less than ½ mile from the station will walk, and others will not.

However, surveys of walk access trips show that the mean rapid transit walk access trip length is nearly 0.5 miles, and that many pedestrians walk more than 0.5 miles to access rapid transit. This indicates that the traditional focus on only the first half mile may underestimate the actual potential for walking trips. In addition, the research shows that there are many factors other than distance that affect the decision whether to walk, including urban design, pedestrian facilities, crime, and individual characteristics. By considering these factors, agencies have the potential to increase walking mode share to stations (33).

**Exhibit 7-1. Example of a traffic signal on a pedestrian route connecting BRT and heavy rail stations (North Hollywood Station, Los Angeles).**



**Source:** Kittelson & Associates, Inc.

The following issues are therefore essential to consider when designing pedestrian access to a station:

- **Directness and speed of route.** Pedestrians want direct walking routes, with minimum delays when crossing streets.
- **Safety and security.** Pedestrians need to perceive that their route is secure and visible to other road users, particularly in the evening. Highway safety is also important, particularly when crossing busy roadways (Exhibit 7-1). Overall roadway design issues are discussed in the chapter on automobile access.
- **Pedestrian-friendly design.** Lighting, building setbacks and orientations, and sidewalks are important determinants of whether a pedestrian feels like an “unwelcome guest” or perceives that the street is designed to meet their needs. They should be designed at a “human scale.”
- **Information.** New, occasional and visiting travelers particularly need wayfinding information to reach local destinations (34).

## Design Principles

There are two primary components of pedestrian station access: (1) station approaches and areas adjacent to stations and (2) station entrances and platforms.

The latter is primarily outside of the scope of this research effort, and is covered extensively in other guidance documents. For example, Part 7 of *TCRP Report 100: Transit Capacity and Quality of Service Manual, 2nd Edition* provides detailed information on pedestrian level of service and circulation on walkways, stairways, queuing areas, and other station elements. *TCRP Report 69: Light Rail Service: Pedestrian and Vehicular Safety* provides information on incorporating pedestrian safety into light rail station design, including appropriate pedestrian control devices and rail crossing treatments. In addition, numerous transit agencies have station design guidelines or criteria covering pedestrian circulation, safety, and queuing within stations. ADA standards also play a major role in transit station design.



The remainder of this chapter focuses on pedestrian access beyond the station entrance. Note that the following guidelines serve only as general principles; detailed design guidance for pedestrian facilities are available from a variety of sources (e.g., TCRP, US Access Board, AASHTO, NCHRP, state departments of transportation, and transit agencies). The guidance is based on the researchers' observations, as well as a synthesis of guidance from the access guidelines for BART, WMATA, and Denver RTD.

### **Design Pedestrian Routes Within the Station to Be Direct and to Minimize Conflicts**

- Minimize walking distances, while ensuring that sufficient circulation space is provided. People always seek the shortest walking route to their destination; station design should recognize this. The *Transit Capacity and Quality of Service Manual* provides detailed procedures for calculating the pedestrian capacity and level of service of walkways based on actual or anticipated pedestrian demand.
- Provide sufficient space through waiting areas (e.g., feeder bus stops) to safely accommodate demand for both waiting passengers and through pedestrians.
- Minimize elevation changes or avoid them altogether wherever possible. Where necessary, ramps, small inclines, escalators, or elevators should be provided instead of, or in addition to, steps (Exhibit 7-2).
- Keep pedestrian routes clear of structural elements such as pillars, to increase accessibility, ease circulation, and maintain visibility and security. All routes should meet ADA requirements for accessibility.
- Locate information points, such as real-time information displays, in locations that avoid impeding pedestrian flows. Adequate space should be provided to allow customers to stand out of travelways while reading displays. The bottom of a stairway, for example, is an inappropriate location.
- Wherever possible, provide multiple access routes to increase accessibility from all directions and to help distribute the flow of people during peak travel periods.
- Introduce traffic calming measures as necessary to control vehicle speeds in the station area.
- Design pedestrian routes to meet accessibility standards for people with disabilities.

**Exhibit 7-2. Pedestrian ramp providing station access (County Line RTD Station, Englewood, CO).**



Source: Kittelson & Associates, Inc.

- Create visible pedestrian pathways through parking facilities delineated by sidewalks or surface markings.
- Design pedestrian waiting areas with enough space to accommodate passengers waiting to be picked up, with lighting, seating, and weather protection. It may be possible to combine transit and drop-off waiting areas, providing that automobiles do not delay transit vehicles.

### Create a Strong Sense of Security for Customers

- Ensure that station agents and other staff have a highly visible presence. If station agents are present, their post should be able to view all entrance points and circulation areas. The prominent use of closed circuit television (CCTV) should be considered where this is not possible.
- Avoid blind corners, alcoves, and other secluded locations.
- Ensure that shrubbery or other pedestrian enhancements do not block visibility of pedestrians or create hidden areas that create a security risk.

### Passengers Should Be Able to Orient Themselves Quickly and Easily

- Minimize the need for wayfinding through direct line-of-sight connections along pedestrian desire lines where possible, particularly to bus stops, connecting rail platforms, and parking areas.
- Avoid changes in direction and blind corners, which can disorient customers.
- Where line-of-sight connections are not possible, provide wayfinding within stations, particularly to parking areas, bus and rail transfer points, and key local destinations.
- Wayfinding should be consistent across stations. Typefaces and symbols should be legible and signs should not be obscured by other signs or equipment.
- Prominently display maps in each station to enable customers to locate destinations. Maps should include station plans, locations of parking, transit connections, bicycle racks, the local street network, and key nearby destinations (Exhibit 7-3).
- Design the station to be as visible as possible from the surrounding area. Where stations are incorporated into other built structures, they should have a distinctive street presence.

**Exhibit 7-3. Local area map within station (Oakland, CA).**



Source: Kittelson & Associates, Inc.

### **Create a Network of Safe, Direct, and Appealing Walking Routes to the Station**

- Allow pedestrians to exit directly onto the street sidewalk without passing through a parking area or bus transit center. Where this is not possible, pedestrian routes and crossing points should be clearly marked and as direct as possible (see Exhibit 7-4).
- Use a variety of design treatments to ensure safe and comfortable pedestrian crossings of roads and driveways in the station area. These can include marked crosswalks, traffic signals, median islands, and curb bulb-outs (see Exhibit 7-5). There are a wide variety of sources available to assist in the planning and design of safe and effective pedestrian crossing improvements. These include the *Manual on Uniform Traffic Control Devices* and *TCRP Report 112: Improving Pedestrian Safety at Unsignalized Crossings*.
- Do not compromise pedestrian safety to accommodate greater auto volumes. Double right-turn lanes and free right-turn lanes should be avoided throughout the station area and particularly along primary pedestrian routes.
- Incorporate pedestrian-friendly design and operations into the traffic signals in the vicinity of the station (e.g., pedestrian signal-heads with countdown timers, adequate pedestrian clearance time, and well-marked crosswalks). As appropriate, additional improvements such as leading pedestrian intervals, curb extensions, and exclusive pedestrian phases should be considered.

**Exhibit 7-4. Example of a pedestrian route through a station parking area (Sound Transit Tukwila Light Rail Station, WA).**



**Source:** Kittelson & Associates, Inc.

**Exhibit 7-5. Rapid-flash beacons at pedestrian crossing treatment leading to station entrance (Metropark, NJ).**



**Source:** Kittelson & Associates, Inc.

- Provide lighting at a pedestrian scale, with particular attention paid to locations with potential vehicle–pedestrian conflicts.
- Provide trees, wider sidewalks, and seating and other street furniture to make routes more appealing to pedestrians. Shade or shelter from wind may be a priority in different neighborhoods, depending on prevailing climate. The *Highway Capacity Manual 2010* procedures for calculating pedestrian level of service (described in detail in Appendix B: Evaluation Tools) can be used to evaluate the quality of both existing routes and potential improvements.



## CHAPTER 8

# Bicycle Access to Transit

Bicycling as a mode of transportation is increasing rapidly in the United States. A recent study of bicycling reports that bike commute mode share rose by approximately 50 percent between 2000 and 2009, and National Household Travel Survey data shows 49 percent more utilitarian cycling trips in 2009 than 2001. This increase is not occurring everywhere, however; areas that have invested in bicycling have experienced far greater increases than those that have not (35). For example, bicycle commute mode share increased more than five-fold in Portland, Oregon, between 1990 and 2009 (1.1 percent to 5.8 percent) while Charlotte, North Carolina's, mode share remained constant at 0.2 percent, according to U.S. Census Bureau data.

Paralleling national trends, this guidebook's case studies suggest that bicycle access to rapid transit stations is an increasingly important concern for transit agencies. Moreover, transit agencies located in urban areas where cycling is rapidly increasing are more likely to be actively engaged in efforts to improve bicycle access to transit. For example, TriMet plans to provide sufficient bicycle parking for its new Portland–Milwaukee light rail line to accommodate bicycle access mode shares of 10–25 percent, depending on the station.

In general, transit agencies wish to achieve two goals related to bicycle access: (1) increase total bicycle access to support transportation agency and community goals for higher bicycle ridership; and (2) establish effective means of accommodating bikes within the transit system, whether through bicycle storage facilities at the station or on-board transit vehicles. These two goals are not always compatible, as increasing bicycle access also has the potential to overwhelm transit system capacity when passengers choose to bring their bicycles on-board (Exhibit 8-1). During case studies, several transit agencies (e.g., LA Metro, BART, and TriMet) expressed a desire to develop bicycle storage solutions that appeal to more bicyclists, due to concern over the inability to accommodate the number of bicycles being brought on-board transit vehicles.

Bicycle access to rapid transit stations improves transit service quality, increases mobility options, and reduces reliance on auto access. It can also enhance rapid transit ridership by:

- Extending the range that patrons cover to reach rapid transit stations, particularly in locations with limited park-and-ride capacity; and
- Increasing the flexibility that customers have to reach destinations at the end of a rapid transit trip. Bike sharing facilities at destination stations (Exhibit 8-2) can help passengers reach more distant destinations without having to bring a bicycle on-board a rapid transit vehicle.

Bicycling makes it possible to increase ridership without a corresponding investment in automobile infrastructure or additional bus service. Most rapid transit riders are willing to walk ½ mile to a station (equivalent to about 10 minutes); they can travel more than two miles by bicycle in the same amount of time. This results in a catchment area that is 16 times that for a pedestrian trip. Moreover, improving bicycle access requires relatively little land, capital investments, or operating funds, and there are almost no associated environmental impacts.

**Exhibit 8-1. Bicycles on-board a light rail vehicle (Los Angeles).**



Source: Kittelson & Associates, Inc.

## Interagency Coordination

As described in Chapters 2 and 6, interagency coordination is critically important to achieve improved transit access; this is also true for bicycle access as the responsibility for providing safe and comfortable bicycle routes to the station usually falls on the local jurisdiction or state DOT rather than the transit agency (which is typically responsible only for the land it owns). As a result, transit agencies may not be able to achieve many of the design principles for access routes listed below without coordination with roadway agencies. Bicycle parking at stations, conversely, typically is the primary responsibility of the transit agency.

**Exhibit 8-2. Bike sharing facility (Denver).**



Source: Kittelson & Associates, Inc.

Local jurisdictions that support bicycle transportation help create bicycle networks that provide access to transit stations. Both Portland, Oregon, and Arlington County, Virginia, adopted land use and multi-modal transportation master plans that emphasize non-motorized access to rail stations. Overall, a strong relationship between a community's comprehensive plan and master transportation plan is needed. Bicycle access to Toronto's GO Transit system varies by the quality of the bicycle network to each station. Stations sited with local street access and bicycle lanes on the streets approaching the station have higher bike-to-rail use. Transit agencies may also experience increases in access by bicycle where a trail connection to a station exists, such as is the case with WMATA's Hyattsville Metrorail station (Northwest Branch Trail), MBTA's Alewife Station (Minute Man Bicycle Trail), and Pittsburgh's First Avenue LRT station (a riverside bicycle trail).

While transit agencies may not be able to implement bicycle route improvements unilaterally, they can play an important role in ensuring that improvements occur. For example, LA Metro's bicycle program provides a good example of how a transit agency can help to guide bicycle improvements on the local roadway system. Metro's 2006 Bicycle Strategic Plan focuses on integrating bicycles with both rail and bus transit. The plan identifies a total of 167 bicycle-transit hubs in the region on which to focus resources.

LA Metro's plan also includes a description of audit procedures for evaluating obstacles for bicycle access with an accompanying audit table (also available electronically from Metro) and a toolbox of bicycle facility design measures that address the purpose of each facility, where to use it, and guidelines on developing it (including photos and diagrams). To support bike-to-transit access at these hubs, Metro has conducted approximately 20 station-specific bicycle access plans, but ultimately relies on individual jurisdictions to ensure that bicycle access is a priority. This strategy has been somewhat successful; for example, the City of Long Beach recently completed a Pedestrian and Bicycle Access Study to its light rail stations complementing Metro's Bicycle Strategic Plan.

## **Factors Affecting Bicycle Access**

Similar to walking, the decision to bicycle to transit stations depends on a combination of factors. These factors include, but are not limited to, safety (perceived and actual), station characteristics, network connectivity, transit agency policy, and surrounding land use. Essential characteristics for encouraging cycling to transit include secure bike parking and high-quality connections to the surrounding road network.

A review of international literature shows that it is possible for bicycles to comprise up to 40 percent of transit access trips (36). However, realizing such a high percentage largely depends on factors outside transit agency control, as system-wide quality of bicycle facilities, topography, weather, and bicycle culture all play large roles in people's willingness to bike. A recent study of 280 bicyclists and auto travelers living within 2 miles of the train and light rail station at Centennial Plaza in Mountain View, California, found six predictors for its bicycling versus driving model: trip distance, trip purpose, car availability, race, gender, and proximity to auto-friendly streets (37).

In addition, climate and weather affect individual bicyclists differently. Bicycle ridership in areas with colder climates and a good bicycling network stays relatively level when the weather is colder. Days with shorter daylight hours reduce bicycle ridership. Wind and rain generally affect daily bicycle access more than temperature (38). Topography may also impact bicycle access, but high-quality facilities may offset the negative impact of hilly terrain. Even so, research indicates that provision of bicycle facilities at transit stations, in particular high-quality bicycle parking, has a significant impact on bicycle access (32).

**Exhibit 8-3. Bicycle mode shares for selected transit agencies.**

Bike Access Mode Share	Number of Stations		
	BART	Denver RTD	NJ Transit <sup>b</sup>
0 – 2 percent	12 (28%)	18 (62%)	61 (90%)
2 – 4 percent	19 (44%)	7 (24%)	6 (9%)
4 – 6 percent	7 (16%)	3 (10%)	1 (1%)
> 6 percent	5 (12%)	1 (3%)	0 (0%)
Total Stations <sup>a</sup>	43	29	68

Notes: <sup>a</sup>Reflects total number of stations for which data were available.

<sup>b</sup>Data are for northern New Jersey commuter rail stations.

Because of the strong role of these factors on bicycle access, the extent to which bicycles are a viable access mode varies considerably by system and even between stations within individual systems. For example, BART's system-wide bicycle access mode share of 2.7 percent is over three times the mode share for NJ Transit commuter rail stations. In addition, according to BART's 2008 passenger survey, bicycle access mode share ranges from less than 2 percent at many outlying stations to over 11 percent at the Ashby Station in Berkeley.

Bicycle access to stations along the MBTA rapid transit lines in the Boston area usually have 2 to 3 percent boardings by bicyclists; one of the highest rates of bicycle access is at the end-of-the-line Alewife Station where bicyclists account for more than 5 percent of the total.

Exhibit 8-3 shows the distribution of bicycle access mode shares for individual stations for selected transit agencies for which data were available. This table shows that agencies differ widely in the amount of bicycle access to transit, with over 70 percent of BART stations experiencing at least 2 percent bike access mode share compared to fewer than 10 percent of NJ Transit stations.

The lower bike access mode shares in New Jersey indicate several potential issues affecting bike access. First, since the New Jersey stations surveyed are all commuter rail, the stations serve suburban areas that may require longer access journey distances and discourage cycling. Moreover, difficulty storing bicycles in Manhattan, which is a major destination of commuters, may discourage riders. In addition, the lower level of bicycle access likely reflects the poorer quality of the cycling environment in New Jersey compared to the Bay Area and Denver. This is supported by the fact that New Jersey generally has lower overall levels of bicycling for all trip purposes than do the Bay Area and Denver.

As a result of the wide range in the popularity of bicycle access, some transit agencies are currently dealing with rapidly increasing bicycle access and bicycle-capacity problems on-board transit vehicles (e.g., Lane Transit District [Eugene, Oregon], BART, LA Metro), while others have fewer current concerns and place less emphasis on bicycle access. Given the general growth in bicycle use, routine consideration should be given to providing bicycle facilities that accommodate 5 percent of boardings, with bike parking sufficient to accommodate 10 percent or more of total boardings in special circumstances.

## Bicycle Access Improvements

Many cities throughout the United States and Canada have undertaken a range of measures to improve bike–transit integration. The main groups of measures are:

- Bike paths, bike lanes, and other on-street routes leading to stations;
- Bike parking at rapid transit stations with varying degrees of shelter and security;



- Multi-functional bike stations that provide not only parking, but also a range of services such as bike rentals, repairs, and accessories; and
- Special accommodation of bikes on-board transit vehicles through racks, hooks, designated loading doors, or other means.

These areas of improvement are described in detail below.

### **Bicycle Access Routes**

Safe and comfortable bike facilities on routes leading to and from transit station are critical components to increasing bicycle access to transit stations. The following ideas serve as general principles; there are numerous design guidelines available for bicycle facilities both nationally (e.g., *AASHTO Guide for the Development of Bicycle Facilities*, *NACTO Urban Bikeway Design Guide*) and locally. The following general principles apply to developing an effective bicycle network in the vicinity of transit stations:

- Provide appropriate bicycle facilities that follow local best practices for bicycle design (e.g., bike lanes, shared-lane markings, and trails) on routes to and from transit stations. Provide bicycle detection at all traffic signals near stations and at station entrances. The *Highway Capacity Manual 2010* procedures for calculating bicycle level of service (described in detail in Appendix B) can be used to evaluate the quality of existing routes and potential improvements.
- Provide bicycle wayfinding to the transit station from adjoining streets and bikeways (Exhibit 8-4).
- Provide area maps in the station locating surrounding streets, popular destinations, and existing bikeways.

In addition to providing bicycle facilities on routes leading to stations, agencies should also establish safe and efficient routes for bicyclists to reach the station entrance or bicycle parking from adjacent streets. To the extent possible, bicycle routes through station property should be as direct as possible and should minimize conflicts between bicyclists, pedestrians, automobiles, and buses. It is also best to avoid the use of sidewalks as bicycle routes wherever possible and

**Exhibit 8-4. Bicycle wayfinding through station parking lot (El Monte Busway Station, Los Angeles).**



Source: Kittelson & Associates, Inc.

**Exhibit 8-5. Bicycle facility through the Rose Quarter Transit Center (Portland).**



Source: © 2011 Google

avoid requiring bicyclists to ascend and descend stairs. Where cyclists must navigate stairs, stair channels allow riders to wheel bicycles up and down stairs.

While some level of conflicts between bicyclists and transit vehicles near station entrances may always occur, design options should be sought to minimize them. TriMet's 2008 redesign of its Rose Quarter Transit Center to improve bicycle conditions and increase safety is a good example of redesigning an existing facility to better accommodate bicycles. Exhibit 8-5 depicts the new bike facility, which reduces bike–bus conflicts by allowing bicycles to travel through the center of the facility while buses serve passengers on either curb.

## **Bicycle Parking and On-Board Accommodation**

### *On-Board Accommodation*

Policies for bicycle access also need to address whether bicyclists park their bicycle at the station or take their bicycles on-board transit vehicles. Agencies that permit cyclists to bring their bicycle on-board the transit vehicle can encourage bicycle access. Allowing bicycles on-board can significantly expand the reach of a transit system as riders can use their bicycle for both access and egress. However, space constraints on transit vehicles during peak periods causes many agencies to restrict bicycle access during those hours or prohibiting it altogether. If bicycles cannot be brought onto the vehicle, safe and secure parking must be provided.

On-board policies can affect the need for bicycle parking at stations. For example, if bicycles are permitted during rush hours, fewer riders may want or need to park their bicycles at rail stations. Eugene's LTD EmX BRT buses are designed for level boarding so bicyclists can walk their bikes on board. Bicyclists board through the rear door of the vehicle, and up to three bicycles can be

accommodated per vehicle. Eugene has very high levels of bicycle ridership, and in many periods demand to bring bicycles on-board exceeds capacity.

Most agencies allow bicycles on-board rapid transit vehicles, and all of the rail agencies interviewed as part of the research allow bicycles on-board during non-peak periods. On-board accommodation during peak periods varies by agency and is largely dependent on overall demand. Where agencies allow bicycles on-board transit vehicles, vehicles should be designed to efficiently store bikes without blocking doors or creating a nuisance for other passengers. Several design options for accommodating bikes are available, such as exterior bicycle racks on buses (Exhibit 8-6), and bicycle hooks and bicycle holding areas inside rapid transit vehicles (Exhibit 8-7).

On many systems with high bicycle access mode shares, there is a desire to encourage more riders to park their bicycles at stations rather than bring them on-board vehicles. To achieve this goal, bicyclists must perceive parking at rail stations to be safe, which requires that the parking be located appropriately and of an acceptable type (e.g., lockers in addition to racks).

To deal with increasing numbers of bicycles on its system, LA Metro promotes both bicycle parking to encourage patrons to leave bicycles at stations when possible, and the use of folding bikes for those passengers that do bring their bikes on-board. Metro is in the early stages of a program that will partner with a local company that promotes green technology, to promote folding bikes and potentially subsidize folding bikes for transit passengers.

Note that there may be equity impacts associated with prohibiting bicyclists from taking bikes on-board vehicles. A survey of over 2,000 bicyclists conducted by LA Metro showed that low-income bicyclists were more likely to bike to transit, and that many of those who bike to transit require use of their bikes on both ends of their transit trip, requiring them to bring their bicycles on-board transit vehicles (39).

### ***Bicycle Racks***

Bicycle racks are the most common method of bicycle parking. Most agencies stated that bicycle racks are relatively cheap and can be installed as needed to meet demand, except where space constraints prohibit additional racks. However, bicycle racks may be less secure than other forms of bicycle storage, making some bicyclists hesitant to use them. The following are general

**Exhibit 8-6. Exterior bicycle rack on BRT vehicle (Los Angeles).**



**Source:** Kittelson & Associates, Inc.

**Exhibit 8-7. Interior bicycle storage examples.**

(a) Bicycle Hook (Portland)

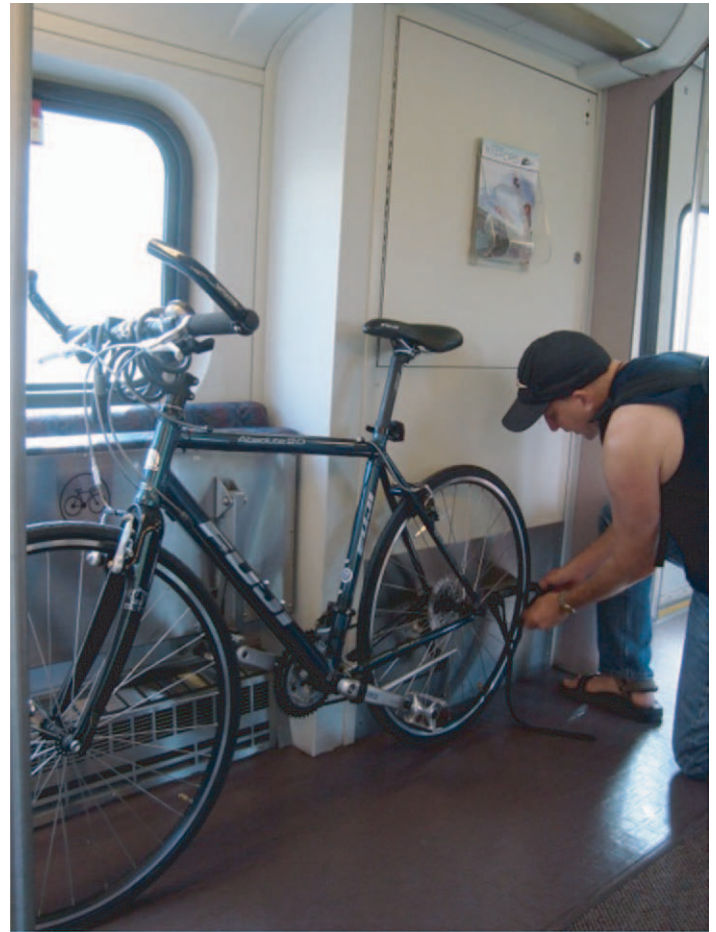

(b) On-board Storage Area (Metrolink)

Source: Kittelson & Associates, Inc.

principles for providing bicycle racks at transit stations (the Association of Pedestrian and Bicycle Professionals' *Bicycle Parking* guidelines provides detailed guidance on bicycle parking):

- Provide adequate bicycle racks to meet demand, wherever space permits.
- Locate bicycle parking in secure, well-lit locations along bicyclists' "desire lines" from major bikeways to the station entrance(s). If it is not possible to site bicycle parking within view of station personnel (if present), parking should be located in areas with high pedestrian flows or where other informal surveillance is possible. However, racks or lockers should not impede pedestrian flows.
- Locate bicycle parking where weather protection exists (such as a roof or awning), where possible (Exhibit 8-8).
- Consider providing covered parking in other locations.
- Locate bicycle parking so that bicyclists do not have to dismount and walk to access it. This means that bike routes should continue as close as possible to the station entrance. Signs requiring bicyclists to dismount generally have limited effectiveness.
- Locate bicycle parking in proximity to station entrances wherever possible.
- Design parking garages to avoid major conflicts with bicycle traffic at structure entrances and exits. Where bicycle routes must cross garage entrances or exits, provide additional traffic control or calming devices to alert motorists to the bicycle crossings.

**Exhibit 8-8. Bicycle racks located beneath overpass (MacArthur BART Station, Oakland).**



**Source:** Kittelson & Associates, Inc.

***Secure Bike Parking***

There are a variety of options for bike storage that provide more security than bike racks. Exhibit 8-9 summarizes the primary methods of secure bike storage.

Bicycle lockers rented through individual subscriptions are the most common method of providing secure bicycle parking, and are in use at many transit agencies (Exhibit 8-10). Lockers are typically rented either annually or semi-annually for a small fee (typically less than \$100 per year). Transit agencies may manage the subscriptions and maintenance themselves, or partner with other organizations (e.g., a local bicycle advocacy organization, a regional MPO) to manage larger parking operations.

While subscription lockers are relatively easy to install and manage, the experience at many transit agencies has been mixed: locker subscriptions tend to sell out quickly but utilization is very low on a daily basis. This suggests that the low price of a subscription encourages occasional bicycle commuters to rent a locker even if they use it infrequently.

As a result, many agencies are exploring more effective options for providing secure bike parking. For example, BART is moving toward hourly payment for bicycle lockers through electronic cards to improve utilization. Similarly, LA Metro recently piloted an unmanned bicycle storage module with electronic entry at the Covina Metrolink station. The facility cost approximately \$100,000 to install. Metro is currently monitoring use to determine whether such facilities make sense in other locations as well.

Attended bicycle parking (Exhibit 8-11) has also proven popular among patrons, but the costs of operating attended bike parking often limit its use within a system to only a few locations. Typically, attended bike parking is combined with other services, such as bicycle repair or rentals, to generate some revenue to pay for operations.

***Bike Sharing***

Bicycle sharing programs are expanding rapidly around the country, many of which are focusing on expanding the reach of transit. Boston and Washington, D.C., for example, have both recently implemented wide-spread bike sharing programs. Bike share stations are placed near MBTA and WMATA stations allowing riders to ride between home and work and the nearest transit station.

**Exhibit 8-9. Summary of secure bike storage options.**

	<b>Bike Stations</b>	<b>Bike Lockers: Subscription</b>	<b>Bike Lockers: Shared System</b>	<b>Self-Service Bike Cage</b>
Description	Provides valet attended parking. Other services (lockers, changing rooms, showers, bicycle repair, etc.) optional.	Metal or plastic crates for storing bicycles. Self-serve.	Metal or plastic crates for storing bicycles. Self-serve.	Bicycle racks behind a locked door. Free-standing cages, or fenced-in room.
Method of Access	Electronic key access, must purchase membership.	Subscribers assigned a specific locker.	Electronic key accesses network of lockers on first-come, first-served basis.	Electronic or other entry through door for subscribers.
Typical Fees	Monthly/annual subscription.	Deposit and monthly/annual fee.	Fees charged electronically by use (several cents per hour).	Monthly/annual subscription.
Benefits	High level of service and security.	Users guaranteed a spot. More secure than racks.	Higher utilization than subscription lockers. Users pay only for what they use. More secure than racks.	Lower operating costs than attended parking. More secure than open racks. High potential utilization.
Cons	High capital and operating costs. Additional agency-owned infrastructure.	Potential for patrons to store items other than bicycles. Waitlists for subscriptions common. Low utilization.	Potential for patrons to store items other than bicycles. Electronic payment system increases operating costs.	Additional agency-owned infrastructure. Lower security and service to patrons than attended parking.

**Exhibit 8-10. Rental bicycle lockers (Oakland).**

Source: Kittelson & Associates, Inc.

**Exhibit 8-11. Attended bicycle parking (Berkeley, CA).**



**Source:** Kittelson & Associates, Inc.

Large bike sharing stations are located outside South Station in Boston and Union Station in Washington, D.C. Bike sharing is attractive especially to commuters and visitors who can often reach destinations more quickly than by connecting to another transit service.

Providing for bike share access to transit has many of the same considerations of other types of bicycle access, including the quality of the surrounding bike network. However, effective bike sharing has the potential to reduce the need for dedicated bike parking. Agencies should work closely with bike share providers on the placement of bike share stations and on choosing which stations may offer the greatest benefit.

# Transit Access

Bus (and in some cases rail) is the major alternative to driving for rapid transit riders that live more than ½ mile from rapid transit stations. It can expand the station catchment area considerably, particularly for riders that do not have a car. It is also an important access mode for the elderly and mobility disadvantaged. Finally, it reduces the land requirements around stations that would otherwise be required for park-and-ride.

Bus access to stations generally accommodates about 25 to 35 percent of station boardings (except at outlying commuter rail stations where there is little or no service availability). Examples of feeder transit mode shares for BART and Denver RTD shown in Exhibit 9-1 and Exhibit 9-2, respectively, illustrate the importance of bus access.

At major outlying transit centers, often the outermost stations, buses account for 50 to 75 percent of all station boardings:

- 95th Dan Ryan, Chicago 75 percent
- 79th Dan Ryan, Chicago 60 percent
- Forest Hills, Boston 60 percent
- Sullivan Square, Boston 53 percent

The passenger transfer between bus stops and rapid transit stations should be safe and convenient, and walking distances to and from station platforms should be kept to a minimum (Exhibit 9-3). Connecting bus services should be frequent, and buses should not be overcrowded. Fare structures should not inhibit the transfer. The guidelines that follow show how these objectives can be realized.

## General Planning Guidelines

The following guidelines will prove useful in developing the type and design of bus transit access to rapid transit stations. Additional design guidance is available in the *Transit Capacity and Quality of Service Manual* (40). The type and design of the bus-to-rapid transit transfer facility will depend on the station location, the number of buses to be accommodated, pedestrian movements, and traffic engineering considerations. Key considerations include: the type of vehicles to be served (buses, electric trolleybuses, streetcars, LRT); location (on-street, off-street); service frequencies and patterns; fare collection practices; and pedestrian access to rapid transit stations.

## Facility Location

Transfers between local bus and rapid transit service should be provided wherever the two services intersect. They are especially desirable at the outermost rapid transit stations. Passenger interchange facilities generally should be provided where the following conditions apply:

1. Rapid transit service and local bus services intersect.
2. There is a natural convergence of bus routes on approaches to the rapid transit station.



**Exhibit 9-1. BART system-wide access targets (AM peak period).**

Mode	1998 Mode Share (%)	2005 Targets (%)	2010 Targets (%)
Walk	23.0	24.0	24.5
Bike	2.0	2.5	3.0
Transit	21.0	21.5	22.0
Drop-off, carpool, taxi	16.0	19.0	19.5
Drive alone	38.0	33.0	31.0

Source: BART

**Exhibit 9-2. RTD system-wide access modes (Denver).**

	SW Corridor		SE Corridor
	2001 (%)	2006 (%)	2007 (%)
Walk	12	28	25
Bicycle	2	3	1
Transit	29	29	21
Drop-off	NA	5	5
Other	7	-	3
Carpool	7	-	5
Drive alone	48	35	40

Source: Denver RTD

**Exhibit 9-3. Feeder bus connections located close to station platform (Sound Transit Commuter Rail Station, Kent, WA).**



Source: Kittelson & Associates, Inc.

3. The transfer point is located at an outlying activity center that generates its own traffic.
4. The transfer simplifies service scheduling and dependability over a direct bus routing (for example, the breaking of one long route into two shorter routes).
5. Local bus routes can be rerouted to serve (or already serve) rapid transit service.

The transfer between local and rapid transit services should save at least 5 minutes to the city center, compared to a one-seat ride on a local service. It is essential to provide adequate bus access to the transfer point, including bus priority treatments where needed.

## Facility Type

Station facility operations and layout should provide direct, convenient, and conflict-free pedestrian access between local buses and rapid transit stations. Bringing bus passengers close to station entrances should be accomplished with minimum deviations of buses from their normal routes. Both on- and off-street terminals (and stations) should allow rapid passenger interchange, facilitated bus entry to and exit from the station, and minimal increase in bus miles.

The choice between on-street and off-street bus station locations also depends on where the stations are or will be located, and the character of the surrounding area. Key considerations include land use, development and street system densities, and bus route patterns and volumes. Urban stations in built-up areas will generally favor on-street provisions for new facilities and redesigning existing facilities. Suburban rapid transit stations will be conducive to off-street transfer facilities, especially when bus interchanging volumes are high.

### *On-street Stations*

On-street stations may include existing streets at more-urban locations (Exhibit 9-4), or new streets that are created on transit agency property as part of a TOD project. On-street facilities are

**Exhibit 9-4. On-street bus facility example (Oakland, CA).**



Source: Kittelson & Associates, Inc.

the most efficient in terms of space, and they minimize route deviation that inconvenience through (non-transferring) passengers. They have lower costs and also help to create a more pedestrian-oriented sidewalk. Low volumes of buses and passengers generally can be accommodated with minimum street improvements.

### *Off-street Stations*

Off-street stations are commonly provided in suburban areas where many routes converge at a single location. Sometimes the decision will reflect a trade-off between the needs of through passengers and those transferring to rapid transit. The choice of location should reflect the relative volumes of each group of passengers. Off-street provision, or a combination of on-street and off-street, may be appropriate in the following instances:

- Stations where many buses must layover or wait to provide timed transfers, and there is insufficient curb space to meet this need on-street.
- Stations where the entrance is set back a significant distance from the sidewalk to minimize the distance transferring passengers must walk.

Terminals are sometimes located on the ground floor or along the perimeter of a parking garage. Examples include the Alewife Quincy Center and Quincy Adams garages in the Boston area.

## **Access Objectives and Guidelines**

For surface transit to be a competitive access mode to rapid transit, it must provide passengers with a seamless journey. Walking distances must be short and conflict free, bus service must be frequent, and the bus and rapid transit station environment must be pleasant. Transfers should be free, where possible, and at a minimum fare collection technologies should be integrated with one another.

### **Minimize Walking Distances**

This objective requires placing bus stops and station entrances close to each other, with safe and direct routes between the rapid transit platforms and the connecting bus services. Sometimes, grade-separated pedestrian access over bus stops adjacent to the station entrance should be provided where both pedestrian and bus volumes are very high.

### **Place Bus Stops in Suitable Locations**

Both on-street and off-street bus stops should be placed in suitable locations that make walking routes to stations short and safe (Exhibit 9-5).

- Bus stops should be located to minimize walking distances to station entrances and should avoid the need to cross roadways, particularly busy arterials. Where a roadway must be crossed, the bus stop should be located adjacent to a marked crosswalk. Passengers should not have to cross more than one major roadway.
- Bus stops should be immediately visible upon exiting the rapid transit station.
- Bus stops should be located where they will not block crosswalks, obstruct traffic signals, or be obscured from motorists, bicyclists, and pedestrians.
- Everything else being equal, on-street bus stops are preferable. However, off-street facilities may be necessary to accumulate multiple routes, to serve bus layovers and transfers between bus routes, and to avoid having passengers walk through parking lots.
- Buses should be able to reach off-street transfer facilities via congestion-free routes, including dedicated lanes or roadways where practical. However, buses do not need to be segregated

**Exhibit 9-5. Bus stops located adjacent to rail platform (University of Denver RTD Station, CO).**



Source: Kittelson & Associates, Inc.

from other traffic when no adverse travel impacts are forecast. Sensitive transit-oriented traffic engineering treatments may be necessary.

- Bus access should be separated from auto access when there are more than 10 to 15 peak hour buses entering or exiting the station, or where there are more than 350 parking spaces.
- Bus-only access roads should have a minimum one-way width of 18 to 24 feet. The inside turning radius should be at least 30 feet.

### **Provide Attractive Feeder Bus Service**

Connecting bus service must be frequent and reliable.

- The bus route structure should be direct and clear. Route deviations should be avoided.
- There should be minimal and predictable wait times between modes. Passengers tend to consider time spent waiting for a bus or train as more burdensome than time actually spent traveling. Providing real-time information about transit arrival times helps alleviate passenger uncertainty of bus arrivals and reduces the wait time burden.
- Connecting bus services should operate at relatively frequent headways. Route headways generally should not exceed 10 to 15 minutes in the peak hour, and should not exceed 12 to 20 minutes in the off-peak.
- Route branching should be minimized. It is better to operate fewer services with short headways than many services with long headways.
- The use of coordinated ticketing can avoid the inconvenience and cost penalties of purchasing separate tickets or fares.

### **Provide Access Priorities at Stations**

Feeder transit service at stations (particularly within terminal areas) should be prioritized in order of transfer activity.

- Drop-offs and boardings should be located as close as possible to station entrances.
- Transit facilities for loading and unloading passengers should be located closer to the station entrance than any other vehicle mode.

- The paths between passenger loading and unloading areas and the station entrance should be as short as possible.
- Bus-to-bus transfers and bus-to-rapid transit transfers should be simple and facilitated by minimizing distances between bus stops.
- An integrated fare system should be established to transfer seamlessly between rapid transit and feeder services.

### Improve the Pedestrian Environment

A safe, comfortable, and convenient environment for intermodal transfers is essential. This is, perhaps, the most important component of station access, since the station area is where passengers spend a considerable amount of time. Passengers need to know where they can stand safely. Accordingly, station planning and design should provide:

- Well-marked stops indicating which transit services stop at which locations.
- Real-time passenger information on connecting bus and rail services. This information should be provided at bus stops and in the station itself so that passengers know if they must hurry to the bus stop.
- Easily understandable maps and schedules for connecting bus and rail services at stops (Exhibit 9-6).
- Weather protection, seating, lighting, and trash cans at all bus waiting areas. Bus shelters should be designed to provide continuous shelter between the bus stop and station entrance where possible.
- Shelter design that enables waiting passengers to easily see oncoming vehicles.
- Sufficient space in waiting areas to safely accommodate pedestrian demand.
- Weather protection, possibly including radiator heaters along station platforms and in shelters in cold-climate areas.

### Consider Shuttle Services

Shuttles provide a useful complement to regular transit service, particularly to sites such as hospitals, large employers, shopping districts, office parks, and schools. Some offer timed transfers with a limited number of peak period trains, while many circulate continuously providing random

**Exhibit 9-6. Transit connections display (Los Angeles).**



Source: Kittelson & Associates, Inc.

**Exhibit 9-7. Private shuttle buses serving BART station (MacArthur BART Station, Oakland).**



**Source:** Kittelson & Associates, Inc.

transfers. Most provide free service to eligible riders. Shuttle buses (Exhibit 9-7) are particularly common in the San Francisco Bay Area, and are growing in popularity in many rapid transit systems. Exhibit 9-8 gives examples of shuttles serving BART and CalTrain stations in San Mateo County, south of San Francisco.

Example shuttle services along the east coast include: a University of Massachusetts shuttle to Boston's Red Line; a New Haven shuttle connecting Union Station with the city center;

**Exhibit 9-8. Shuttles by city, San Mateo County, California.**

<b>Brisbane</b>
Bayshore/Brisbane Commuter (Caltrain)
Crocker Industrial Business Park (BART & Caltrain)
<b>Burlingame</b>
Burlingame Bayside Area (BART & Caltrain)
North Burlingame Area (BART & Caltrain)
<b>Foster City</b>
Foster City Connection Blue Line
Foster City Connection Red Line
Lincoln Centre (Caltrain)
Mariners' Island (Caltrain)
North Foster City (BART & Caltrain)
<b>Redwood City</b>
Redwood City Climate Best Express On Demand Service
Redwood City Mid Point Business Park Area (Caltrain)
<b>San Mateo</b>
Campus Drive Area (Caltrain)
Mariners' Island (Caltrain)
Norfolk Area (Caltrain)
<b>South San Francisco</b>
Oyster Point Area (BART)
Oyster Point Area (Caltrain)
Utah-Grand Area (BART)
Utah-Grand Area (Caltrain)
Downtown Dasher – Midday Taxi

employee-oriented shuttles in Norwalk and Stamford, Connecticut; an automated guideway transit (people mover) connection between New Jersey Transit and Amtrak’s Northeast Corridor and Newark International Airport; a rail shuttle serving downtown Princeton, New Jersey; and a shuttle connecting an Amtrak and commuter rail station with Baltimore–Washington International Airport. All of these shuttles serve major special purpose destinations.

Exhibit 9-9 shows the free Green bus shuttle that connects New Haven’s Union Station, downtown New Haven, and remote parking lots. The free shuttle operates at 2- to 20-minute intervals from about 6:20 a.m. to 10:00 p.m. Monday through Friday. The route’s cycle time is 15 minutes.

It is generally preferable to serve employment destinations by regular bus services, as they have more potential to also serve other riders. Accordingly, care should be taken not to duplicate existing bus services.

Effective shuttle services require partnerships between the transit agency and the shuttle service provider. Engaging the community and local employers creates the potential for mutual benefit and leverages a variety of funding sources. This can be challenging in the case of private shuttles, however, as there may not be a clear point-of-contact, and schedules and services often change without notice. See Chapter 2 for more information on improving the planning process and working collaboratively with local partners.

Where parking supply is constrained, shuttle services can be used to connect auxiliary parking facilities with the rapid transit service. The bus transfer, with the additional wait and travel time, makes this an inconvenient option from a customer perspective and may impede the success of

**Exhibit 9-9. Green shuttle bus (New Haven, CT).**



Source: CT Transit

the remote facility. High-quality rapid transit service and frequent shuttle service are needed to make this strategy effective.

## Bus Characteristics

Bus dimensions, design, and internal arrangement, coupled with operating practices, will influence the design of both on-street and off-street interchange facilities.

Selected design characteristics of 40- and 45-foot buses are shown in Exhibit 9-10. Urban transit buses are normally 102 inches (8.5 feet) wide. When bus mirrors are included, the outside envelope becomes about 10 feet. Therefore, a minimum of 11-foot lanes should be used for buses.

**Exhibit 9-10. Design characteristics for 40- and 45-foot buses.**

Characteristic	40-ft Regular Bus	45-ft Regular Bus
Length	40 ft	45 ft
Width without mirror	8.2-8.5 ft <sup>a</sup>	8.5 ft <sup>a</sup>
Height (to top of air conditioning) for design	9.9-11.5 ft <sup>b</sup>	12.5 ft <sup>c</sup>
<b>Overhang</b>		
Front	7.2 ft	7.9 ft
Rear	9.3 ft	9.8 ft
Wheelbase (rear)	25 ft	22.9 ft
Driver's Eye Height	7 ft <sup>c</sup>	7 ft <sup>c</sup>
<b>Weight</b>		
Curb Weight	27,000-28,000 lbs	38,150 lbs
Gross Weight	36,900-40,000 lbs	55,200 lbs
Ground to Floor Height	2.3 ft	2.3 ft
<b>Passenger Capacity</b>		
Seats	45-50	50
Standees (Crush Load)	20	28
<b>Turning Radius</b>		
Inside	24.5-30 ft	24.5-30 ft
Outside <sup>d</sup>	42-47 ft	42-47 ft
Outside with Overhang	45.5-51 ft	45.5-51 ft
Doors – Number (typical)	2	2
Width of each door	2.3-5 ft	2.5-5 ft
<b>Angles (degrees)</b>		
Approach	10°	10°
Breakover	10°	10°
Departure	9.5°	9.5°

Notes: <sup>a</sup> With mirrors envelope becomes 10 to 10.5 feet

<sup>b</sup> Use 16 feet as minimum governing design clearance

<sup>c</sup> Use 3.5 feet design

<sup>d</sup> Add 1.5 feet where buses are equipped with bicycle racks

Exact dimensions may vary by bus manufacturer

**Source:** TCRP Project D-09 Phase II Draft Guide



The table also gives passenger seated and standing capacities for each bus type. The standing capacities represent “crush load” conditions. For schedule design purposes, the standing loads should be about 75 percent of the values cited.

There is increasing use of articulated buses on heavily traveled bus routes. These buses normally are approximately 70 feet long and commonly have three sets of doors.

## Bus Operating Practice and Terminal Design

Several bus operating practices influence transfer facility location arrangement and design.

### Service Patterns

Buses may operate through a rapid transit station area or they may terminate there. Through-routing of buses is common at many interchange points, and is better served by on-street stops with recessed passenger loading areas. Through-routing is generally desirable where most passengers are going to other places along the bus route and are not primarily using the service to transfer to the rapid transit route.

- Outlying terminals provide convenient points for breaking up long routes, especially where the terminals are break points in urban density patterns. Common practice is to reroute buses into the rapid transit stations to encourage the use of rapid transit for longer trips. Stations also can serve as the focal point of an integrated transit center.
- Off-street bus loading areas (bus bays, loops, or terminals) should be provided where there are more than 12 to 15 buses terminating at a single stop and where the stop serves as a staging area for buses, or is at a rapid transit station.

### Terminal Types and Operations

Bus terminals or transfer points may be located on-street or off-street. On-street terminals generally involve reserving curb lanes for passenger discharge and pick-up. Linear transfer areas may be located midblock or they may cover several blocks. Sometimes, recessed bus bays are provided. The bays may be contiguous to the travel lanes, or they may be physically separated. In both cases, buses operate parallel to the general traffic lanes.

Shallow sawtooth bus bays are commonly used at off-street bus terminals and transfer points because they allow independent bus entry and exit. The *Transit Capacity and Quality of Service Manual* provides additional detail on bus bay design considerations and operations (40).

### Bus Operating Sequence

Separate bus berths should be provided for alighting passengers, bus layovers, and boarding passengers. Terminating buses should be able to unload without delay, pass through a holding area where they can unload passengers if the normal berth is occupied, proceed to a layover area, and proceed to a boarding area once the layover is complete. Unloading passengers should have short, direct, conflict-free access to the rapid transit station entrance. Buses should load and unload at the same point only where bus volumes are light or where bus routes do not terminate at the station.

A specific passenger loading area should be designated for each bus route or group of routes. Heavily used routes may need several berths.

## Internal Bus Routing

Roadways used by buses and bus berth configurations should enable buses to circulate in the direction that places the door where pedestrians are boarding. Most commonly, counter-clockwise circulation will bring passengers to external walkways near station entrances. But clockwise circulation patterns works best for center island stations. Maximum separation of pedestrians and vehicle paths should be provided. Bus access should be separated from park-and-ride access if possible (Exhibit 9-11).

## Bus Berth Capacity

The number of bus berth positions should be based on the maximum number of buses expected to use the terminal at any given time. More specifically, berthing requirements will depend upon the number of peak hour passengers, bus dwell times, and berth turnover. Boarding and alighting times depend upon the number of available door channels, the methods of fare collection and number of passengers to be processed, and internal vehicle configurations. Current experience suggests that 20 to 30 berths are a reasonable upper limit for most urban conditions.

The bus facility design should accommodate demands after the rapid transit station is opened and ridership has stabilized. The loading platform and the terminal footpaths also should accommodate anticipated future demands 25 years into the future. Transit agencies normally base berth capacities on actual operating experience.

Berth requirements can be estimated in various ways:

1. They can be based on analogy-comparison of rapid transit station boarding at similar locations along the rapid transit line.
2. They can be based on the various bus capacity equations in the *Transit Capacity and Quality of Service Manual*.
3. They can be based on estimates of the time requirements to board or alight from a fully loaded bus.

**Exhibit 9-11. Bus circulation separated from park-and-ride circulation (Walnut Creek BART Station, CA).**



Source: Kittelson & Associates, Inc.

Passenger service times and bus boarding times can be reduced (and berth throughput increased) by eliminating on-bus fare collections (i.e., pre-paid fares), increasing the number of door channels, and using all doors for passenger boarding or alighting during peak periods and providing bus layovers elsewhere.

### Bus Berth Dimensions

The dimensions of bus terminal facilities depends on the number of buses served, the size of buses (e.g., 40-passenger, articulated, etc.), bus operating policy, and the bus berth design (e.g., linear or shallow sawtooth). Linear bus berths (common in on-street operations) require at least 35 to 70 feet for the bus stops plus at least 15 feet for bus maneuvering. Shallow sawtooth bays (common in terminals) require 65 to 85 feet of linear space. Exhibit 9-12 shows illustrative bus berth configurations.

**Exhibit 9-12. Illustrative bus berth configurations.**

**1. IN-LINE PLATFORM TYPICAL BERTH**

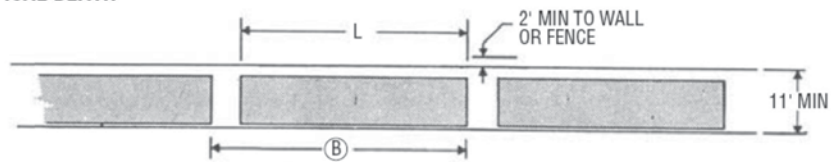

**2. IN-LINE PLATFORM - INDEPENDENT ARRIVALS NORMAL BERTH**

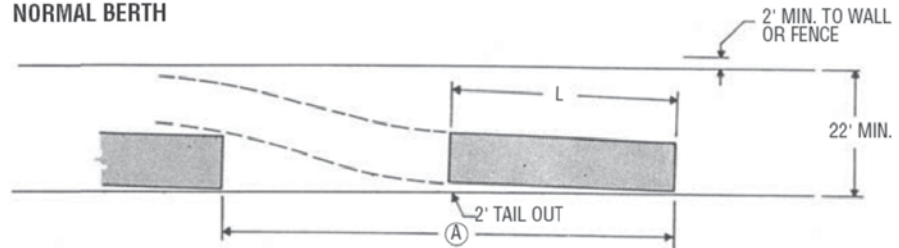

**3. SHALLOW SAWTOOTH PLATFORM**

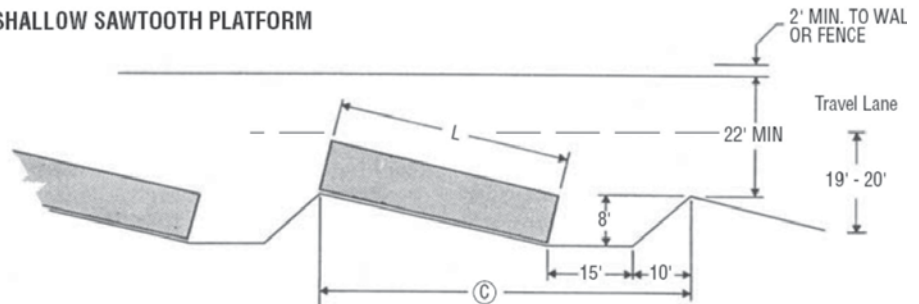

	SINGLE UNIT BUS	ARTICULATED BUS
L	40'	60'
(A)	80'	100'
(B)	45'	65'
(C)	65'	85'

Source: TCRP Report 90 (20)

## Terminal Access And Arrangement

Off-street bus transfer facilities should have direct access from surrounding arterial streets. Street widening, contraflow bus lanes, special bus turn lanes and signals, or even bus grade separations may be desirable to expedite bus flow and minimize conflicts. For example, reserved bus lanes are provided on approaches to Toronto's Eglinton Station; a special left-turn bus lane and traffic signal is provided at Chicago's Jefferson Park Terminal; and a trumpet interchange is provided at Toronto's Warden Terminal. Buses enter Boston's Quincy Adams terminal directly from an adjacent expressway. Sometimes, pedestrian overpasses carry bus passengers over arterial streets.

Terminal arrangements and designs should fit the site and the surrounding street patterns. Thus, there is no "typical" bus terminal layover. The amount of bus traffic, possible points of street access, site configuration and frontage area, freeway interchange design, and topographic features govern the layout of specific bus stations. Roadways used by buses should enable buses to stop as close as possible to station entrances with minimal pedestrian-bus conflicts. The objective is to locate the bus doors on the same side of the roadway as the station entrance.

As a general principle, the bus platform arrangement should be as compact as possible. This may involve passenger boarding parallel to the station track alignment or perpendicular to it. The perpendicular design results in a "hairpin" configuration with pedestrian circulation on and around the perimeter of the bus platforms.

Space between freeway main travel lanes and service roads can be used for bus interchanges when the rapid transit line is located in the freeway median. Initial freeway designs should provide for such facilities. For example, Chicago's 69th and 95th Street Stations incorporated bus bridge terminals in the basic freeway design as a result of advance planning and right-of-way reservation.

## Terminal Design Examples

Some conceptual and actual examples of bus terminals illustrate these guidelines.

### *Arterial Street Bus–Rail Interchange*

An illustrative bus–rail interchange is shown in Exhibit 9-13. The most common type of rapid transit–local transit interchange involves bus turnouts on arterial streets that cross rapid transit lines. Turnouts are located adjacent to station entrance and exit points. The station entrance is located on the side of the street that allows direct pedestrian entry from the major direction of approach. An auxiliary exit can be provided on the other side of the street to minimize midblock pedestrian crossings. A median island with fence may be desirable to preclude midblock pedestrian crossings.

### *Bus Terminal over Freeway and Rapid Transit Line*

An example of a bus station (the 95th/Dan Ryan terminal in Chicago, Illinois) located over a rapid transit line and freeway is shown in Exhibit 9-14. A single bus bridge in conjunction with a pair of new bus bridges adjacent to frontage roads over a depressed freeway provides direct access for buses from city streets. Buses circulate clockwise around a central express transit station. Such a design may be combined with special bus-actuated traffic signals to allow bus entry and exit from adjacent streets. The Dan Ryan bus terminal occupies a 300 foot by 200 foot envelope. The 22-berth terminal serves more than 12,000 passenger boardings each weekday.

**Exhibit 9-13. Bus-rail interchange.**

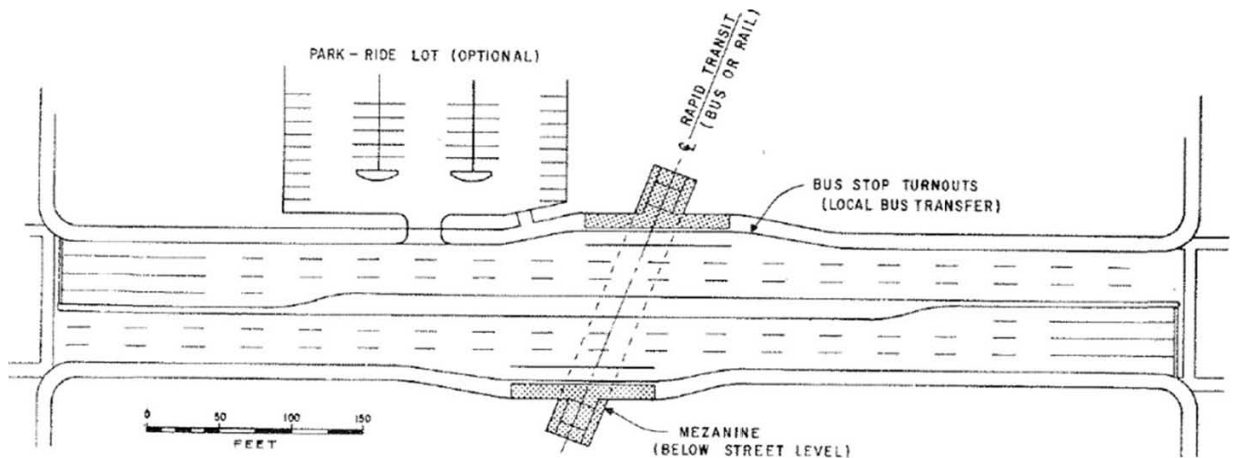

Source: NCHRP Report 155 (41)

*Major Multi-modal Terminal: Journal Square Transportation Center, Jersey City*

There are several examples of multi-modal transportation terminals in control areas of cities that include parking facilities, passenger distribution systems (e.g., circulators), bus terminals, and TOD. This multi-modal transportation and commercial center (Exhibit 9-15) is located at a key station along the Port Authority Trans Hudson (PATH) rapid transit line.

**Exhibit 9-14. Example bus station located over rapid transit line (Chicago, Illinois).**

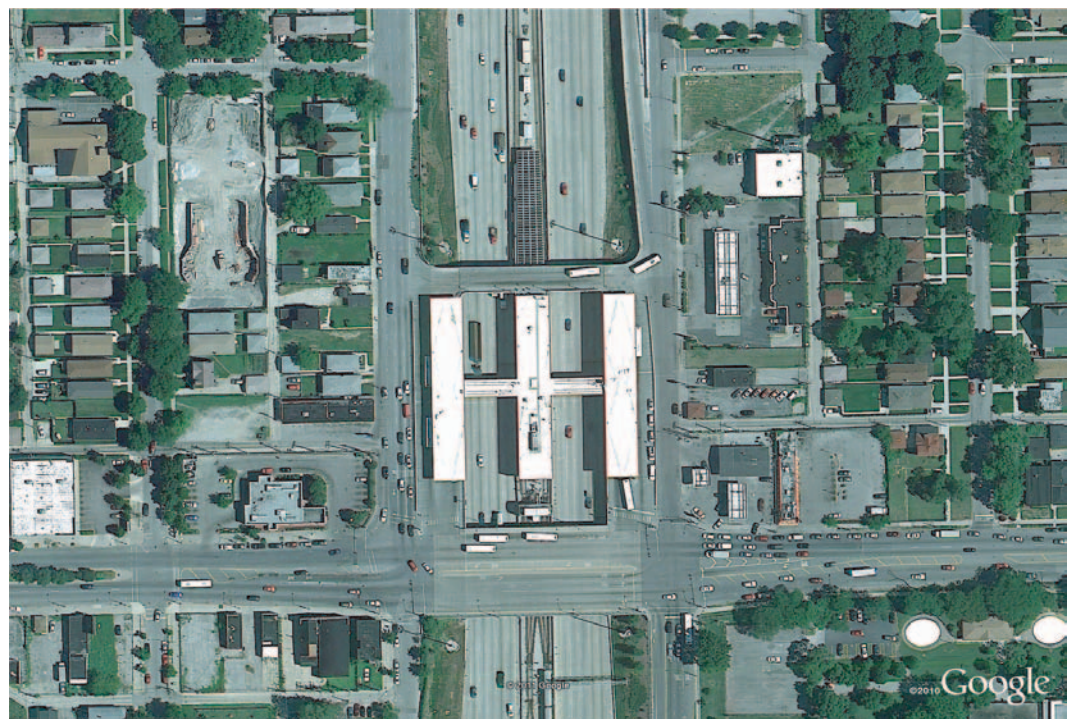

Source: © 2011 Google

**Exhibit 9-15. Journal Square Transportation Center (Jersey City, New Jersey).**



Source: © 2011 Google

It provides a vertically integrated interface among the rail, bus, and auto parking modes that incorporates a 10-story office tower and retail space. A grade-separated bus terminal and a 600-space garage service the PATH trains that run every 3 minutes during peak periods. The center, located in air rights above the PATH right-of-way, has been in operation since 1975. The entire complex is owned and operated by a public agency (Port Authority of New York and New Jersey), so it is institutionally as well as modally integrated. Subsequent to its completion, an element of public-private ownership was introduced when sections of the office tower were sold to major tenants in an office condominium arrangement.



## CHAPTER 10

# Automobile Access and Park-and-Ride

This chapter contains planning, design, and operations guidelines for rapid transit park-and-ride facilities. General planning and policy objectives are discussed first, followed by suggested guidelines relating to operations, policy and planning, design and operation. The materials, which represent a synthesis and extension of current practice, draw upon such reports as: *NCHRP Report 155: Bus Use of Highways: Planning and Design Guidelines* (41), *Parking* (42), *TCRP Report 95: Traveler Response to Transportation System Changes, Chapter 3: Park-and-Ride/Pool* (3), and *Parking Management—Planning, Design, and Operations* (43).

The general approach to planning, design, and operations is shown in Exhibit 10-1. This chapter focuses on the planning, operations, and conceptual design aspects.

### Overview and Objectives

Park-and-ride facilities are integral parts of modern rapid transit. They enable rapid transit and automobiles to operate in the environments that each is best suited to serve. They are essential to attract rapid transit riders from residential areas where densities are too low for walking and bus trips. They extend the reach of rapid transit lines and make rapid transit feasible in suburban settings. Their primary function is to provide a convenient transfer point between autos and rapid transit.

### Why Provide Park-and-Ride

Automobile access to rapid transit stations accounts for about 40 percent of all station boardings in San Francisco and Denver, and similar proportions in other cities. Suburban origin stations often have even higher shares of auto access. Park-and-ride facilities, therefore, contribute substantially to ridership. They also have regional mobility and environmental benefits. They shift CBD and activity center parking demand to outlying locations, thereby freeing downtown space for other uses, reduce travel on radial freeways, and provide convenient access to outlying express transit stations. The provision of park-and-ride facilities recognizes that the likelihood of driving increases in areas further from the city center. It allows the trip to be made by rapid transit, thereby saving passengers travel time and expanding the catchment areas of rapid transit service. The secondary distribution by automobile increases the public transport market, reduces the extent of rapid transit investment, and permits wider station spacing, thereby improving rapid transit operating speeds and reducing operating costs.

Park-and-ride facilities:

- Extend the reach of rapid transit lines beyond the terminal stations;
- Serve CBD employment growth, especially where a lid or ceiling is placed on CBD parking;

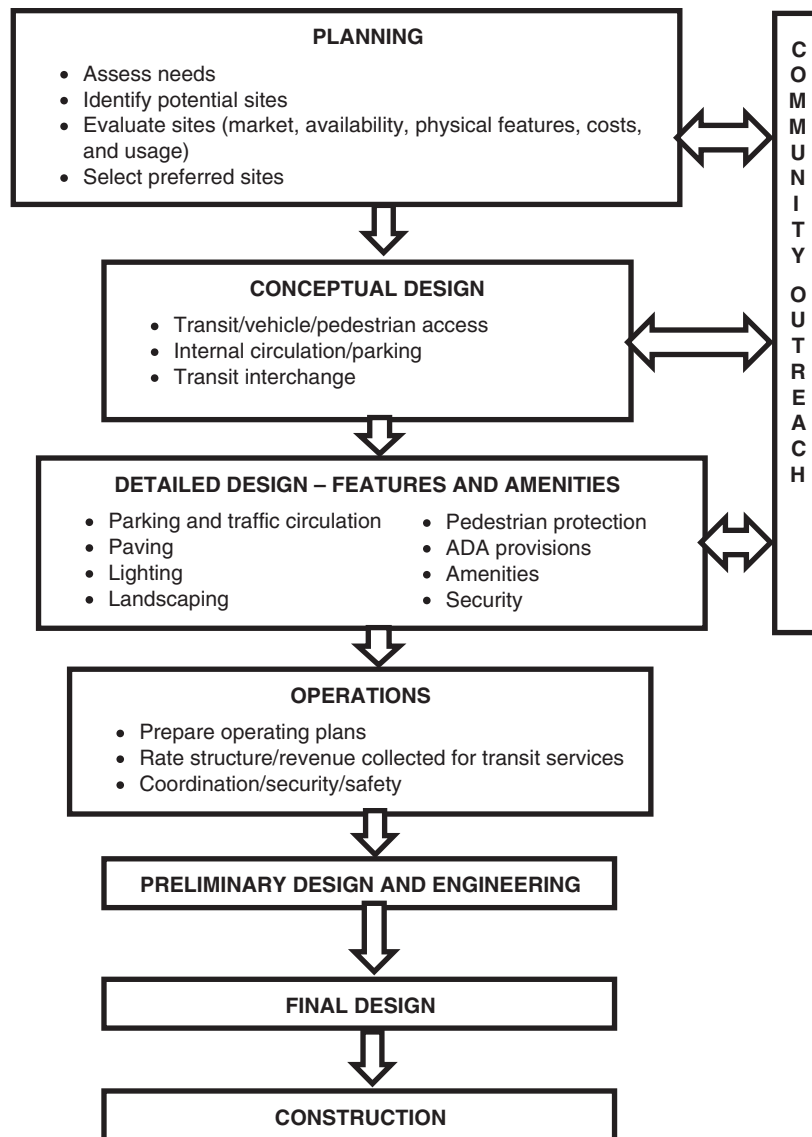
**Exhibit 10-1. Park-and-ride planning and design process.**

Source: *Parking Management* (43)

- Provide station access where station spacing is wide, pedestrian access is difficult, and/or bus service is limited (i.e., headways of more than 15 minutes);
- Build rapid transit ridership when existing park-and-ride facilities are full, providing additional space that can attract new riders; and
- Intercept motorists and remove them from congested sections of roadway, translating into reduced vehicle-miles traveled (VMT) and energy consumption.

### Where to Provide Park-and-Ride

Park-and-ride facilities work best where car travel to the city center and other large activity centers is inhibited by traffic congestion, tolls, costly parking, or a combination of these. The multi-modal trip to the city center should be faster (or comparable), more reliable, and less costly than driving. Ideally, the time savings should exceed five minutes.



Park-and-ride facilities should be provided where one or more of the following factors apply:

- Population densities are too low to support frequent bus service (i.e., where rush hour connection headways exceed 15 minutes);
- The station catchment area is not served by local bus service;
- Locations are at least 5 to 8 miles from the city center;
- Locations are perceived as safe by patrons;
- Facilities are less costly to provide than special feeder bus service;
- Facilities are located near the confluence or terminal points of urban freeways;
- Suitable access from cross streets can be provided; and
- Freeway corridors are congested and park-and-ride facilities can be provided in advance of the congestion.

### **Objectives**

Park-and-ride facilities should help promote the broader objectives of improving mobility and convenience of travelers, encouraging desirable land use and development, minimizing direct public expenditures for transportation, and minimizing adverse impacts on communities (3). They should:

- Increase the availability of alternatives to driving alone, by providing travelers with opportunities to readily transfer from low- to high-occupancy travel modes and vice versa. This allows for a combination of different types of modes (i.e., not only auto–transit, but also bicycle–transit and so on).
- Concentrate transit rider demand to a level enabling rapid transit service that could not otherwise be provided. Without park-and-ride, transit service would be infeasible in many low-density areas.
- Expand the reach of rapid transit into low-density areas, thereby bringing more riders to premium transit services. In some situations, this has been known to induce ridership to the point that service has been increased.
- Reduce VMT, emissions, and energy consumption by enabling motorists to transfer to rapid transit lines.
- Reduce the demand for spillover parking.
- Permit CBD parking demands to be stabilized by providing viable alternative transportation to support economic development in the core.
- Prioritizing carpooling and van pooling for transit patrons may allow for more boardings with the same number of parking spaces. However, use of park-and-ride facilities as meeting locations for carpools and van pools reduces the amount of parking available for transit customers.

### **Extent and Amount of Park-and-Ride**

Peak occupancies of 80 percent or more are common at park-and-ride facilities. The number of park-and-ride spaces that should be provided depends on both specific situations and public policy. Suburban commuter rail and heavy rail transit lines typically provide about one space for every two to three boarding passengers; light rail lines typically provide one space for every three to five boarding passengers.

### **User and Usage Characteristics**

User and usage characteristics play an important role in facility planning, design, and operations. A description of salient characteristics follows.

## User Characteristics

Key travel characteristics of park-and-ride users are shown in Exhibit 10-2. This exhibit shows that most users were previously car drivers or passengers who mainly arrived by car, and traveled mainly to and from work on a daily basis. About half traveled 3 miles or less to the parking facility and most traveled more than 10 miles in total to their destinations, usually in the city center.

Exhibit 10-3 shows the access characteristics for Metra commuter rail service in Chicago, including total parking capacity, parking demand, and access modes of arrival. This exhibit

**Exhibit 10-2. Travel characteristics of park-and-ride users.**

Characteristics	Range (%)	Number of Lots <sup>a</sup>	Average <sup>a</sup>
Previous mode of travel			
Drove alone	11 to 65	305	49.2
Carpool/van pool	5 to 28	303	23.2
Transit (bus or other)	5 to 49	304	10.4
Did not make trip	0 to 29	303	14.9
Arrival mode to facility			
Drove alone	38 to 91	146	72.6
Shared ride	3 to 36	146	11.0
Dropped off	0 to 31	117	11.1
Walked	0 to 21	132	4.4
Bus	0 to 10	132	1.3
Trip purpose			
Work or business	83 to 100	107	97.2
School	0 to 11	80	2.3
Other	0 to 17	80	0.5
Travel frequency (round trips per week)			
Three or less	2 to 15	101	6.6
Four	3 to 16	86	7.6
Five or more	71 to 93	86	86.8
Home-to-lot distance (miles)			
Three or less	6 to 74	163	46.4
Four to six	18 to 42	162	22.8
Six or more	8 to 69	162	29.2
Lot-to-destination distance (miles)			
Less than 10	0 to 100	190	6.9
10 to 30	0 to 100	190	63.2
30 or more	0 to 51	177	30.4

<sup>a</sup> The "average" values shown are weighted by the number of park-and-ride lots surveyed. Partial or missing data from certain studies may cause the percentages not to total 100.

Source: *Parking Management* (43, 44)

**Exhibit 10-3. Metra park-and-ride usage characteristics and mode of arrival.**

	Station Distance to CBD (Miles)				Overall System
	0-10	10-20	20-30	30+	
<b>Weekday boardings (AM peak inbound)</b>					
1986	6,250	40,574	42,000	9,800	98,624
1994	7,938	44,226	46,494	14,742	113,399
Change 1986-94	1,688	3,652	4,494	4,942	14,775
Change 1986-94	27%	9%	11%	50%	15%
<b>Station parking capacity</b>					
1986	2,918	20,676	22,591	7,936	54,121
1994	3,824	24,047	28,134	12,296	68,301
Change 1986-94	906	3,371	5,543	4,360	14,180
Change 1986-94	31%	16%	25%	55%	26%
<b>Station parking use (observed)</b>					
1986	2,493	17,937	20,029	6,538	46,997
1994	3,079	19,647	25,631	10,525	58,882
Change 1986-94	586	1,710	5,602	3,987	11,885
Change 1986-94	24%	10%	28%	61%	25%
<b>Average parking space occupancy</b>					
1986	85%	87%	89%	82%	87%
1994	81%	82%	91%	86%	86%
<b>Mode of station access (1994)</b>					
Drove alone	25%	43%	61%	71%	55%
Walked	59%	34%	12%	6%	21%
Dropped off	10%	13%	14%	14%	13%
Carpool	3%	5%	6%	6%	6%
Bus	2%	4%	5%	2%	4%
Other	1%	1%	1%	1%	1%

Source: Ferguson (5)

shows that parking demand steadily increased to fill the new parking capacity built between 1986 and 1994.

### Parking Supply and Use

Park-and-ride facilities are often used to (or even beyond) their capacities. Exhibit 10-4 gives examples of parking space use for 20 commuter rail, heavy rail, and light rail systems in North America; 14 of the systems were occupied to at least 65 percent of their capacity, although overall utilization varies widely by agency indicating the importance of local factors in determining overall parking demand.

**Exhibit 10-4. Examples of utilization of rail park-and-ride facilities.**

System (Year)	Number of Facilities	Number of Spaces	Parked Vehicles	Percent Capacity
<b>Commuter Rail</b>				
Caltrain (1998)	34	4,125	3,210	78%
Connecticut – New Haven Line[s] (1996)	35 <sup>a</sup>	14,258	12,056	85%
Go Transit – Toronto (1998)	8	32,052	30,139	94%
MARC – Maryland/West Virginia (1995)	26	5,922	5,150	87%
METROLINK – Los Angeles (1999)	46	14,500	n/a	75%
Sound Transit – Puget Sound, Washington (2010)	10 <sup>b</sup>	5,982	5,264	88%
TriMet – Portland, Oregon (2010)	4 <sup>c</sup>	699	280	40%
Virginia Railway Express (1995)	13 <sup>d</sup>	3,901	2,411	62%
<b>Heavy Rail</b>				
Chicago Transit Authority (1998)	15 <sup>a</sup>	6,506	5,1–5,500	78–85%
Metrorail – Miami (1993)	17	9,391	5,030	53%
Metrorail – Washington, DC (1995)	39 <sup>a</sup>	38,137	34,195	90%
Southeastern PA Transp. Authority (1993)	3 <sup>a</sup>	1,133	1,133	100%
<b>Light Rail</b>				
Buffalo (1995)	2	1,400	n/a	70%
Calgary (1998)	11	7,354	7,126	97%
Dallas Area Rapid Transit (1998)	8	4,190	n/a	86%
Denver (2009)	20	11,739	8,517	73%
Sacramento (1999)	9	4,120	n/a	55%
San Diego Trolley (1999)	23	5,553	1,471	26%
Santa Clara Valley Transp. Authority (2009)	21	6,471	1700	26%
TriMet – Portland, Oregon (2010)	23	9,606	5,261	55%

Notes: n/a: Information not available except by inference based on the “Percent Capacity” values, which come from estimates or other derivations used by the reporting agencies.

<sup>a</sup> Parking fee charged at several or all facilities

<sup>b</sup> South Sounder line, includes adjacent and satellite lots

<sup>c</sup> Includes the parking facility operated by the City of Wilsonville

<sup>d</sup> Parking fee charged at several facilities in the survey year (fees since removed)

Sources: *TCRP Report 95 (2, 45, 46, 47, 48, 49, 50, 51, 52, 53, 54, 55, 56, 57)*

## Parking and Boarding Comparisons

The number of boarding passengers per parking space, and the number of parking spaces per boarding at selected stations for heavy rail and light rail transit stations are shown in Exhibit 10-5. Commuter rail stations are shown in Exhibit 10-6.

At commuter rail stations, there are generally 0.4 to 0.6 parking spaces per boarding. At heavy rail and light rail transit stations, the wide range of parking spaces per boarding passenger reflects differing development densities, and reliance on walking, bus, and kiss-and-ride trips at individual stations.

**Exhibit 10-5. Parking spaces and passenger boardings for rapid transit and light rail transit lines (stations with parking in selected cities).**

City	Year	Parking Spaces	Number of Stations	Parking Spaces per Boarding Passenger	Boardings per Space
<b>Heavy Rail Transit</b>					
Atlanta	1990	17,700	9	0.1 – 0.4	2.3 – 13.6
Boston	2005/2006	17,500	15	0.1 – 0.5	1.8 – 8.3
Chicago	2000/2005	6,700	10	0.1 – 0.3	3.3 – 12.3
Cleveland	2005/2006	4,000	10	0.1 – 0.9	1.1 – 12.3
San Francisco	2003	47,100	29	0.1 – 1.1	0.8 – 10.2
Washington, DC.	2000	58,200	33	0.1 – 0.7	1.5 – 16.9
<b>Light Rail Transit</b>					
Boston	2005/2006	2,000	6	0.1 – 0.7	1.5 – 15.0
Cleveland	2005	820	1	1.2	0.9
Portland	2006	7,000	17	0.1 – 0.8	1.2 – 6.7

**Source:** Transit agencies

At rapid transit stations that mainly rely on auto access, there are typically 2.0 boardings per parking space. Half of the stations with parking in the BART system have about 0.4 to 0.6 parking spaces per passenger boarding.

Light rail stations display a wide range of parking spaces per boarding space. However, about half of the stations along TriMet's light rail lines in Portland have between 0.2 and 0.3 spaces per boarding.

## Planning Guidelines

Planning, locating, and selecting park-and-ride facilities calls for assessing and balancing many factors. Sites should be located where there is good highway and transit access, strong rapid transit ridership potential, and locations perceived by passengers as secure. Facilities should be

**Exhibit 10-6. Parking spaces and passenger boardings at selected commuter rail stations.**

System	Spaces	Daily Boardings	Spaces per Boarding	Boardings per Space
Boston (MBTA) – (2005/6)				
North Station	10,418	24,738	0.4	2.4
South Station	21,758	43,879	0.5	2.0
Chicago (Metra) – (2002)	85,563	149,187	0.6	1.7
Toronto (Go Transit) – 2006 <sup>a</sup>	27,180	46,670	0.6	1.7

<sup>a</sup> Sample of system

**Source:** Transit agencies

located on level land of suitable size and shape with minimum environmental constraints, and their locations (and designs) should be acceptable to the surrounding community. Land should be available, development costs should be reasonable, and environmental impacts should be minimal.

The following guidelines cover planning principles, regional location, site selection, facility size, and facility types and costs. The general planning process is covered in detail through the eight-step process described in Chapter 2.

## Planning Principles

Several broad planning principles underlie site locations and selection. The following principles should be considered for any park-and-ride development at or near stations (58).

- Locate transit station parking facilities at a sufficient distance from the city center, where access is good, adequate land is available, and environmental impacts are minimal.
- Maximize the utilization of existing park-and-ride facilities and ensure that the viability of existing facilities is not threatened by a possible new facility.
- Assess the merits of each potential parking location individually, taking into account the likely market and potential demand, as well as the physical, environmental, and cost characteristics of each site.
- Construct facilities that will maximize usage, provide good access to rapid transit lines, and promote reverse commuting.
- Support community integration of park-and-ride facilities, based on local community input.
- Make provisions for the payment of parking fees that could be adopted initially or in the future.
- Balance the needs of pedestrians, bicyclists, and transit passengers with the needs of automobiles.
- Ensure the safety and security of all users.

## Regional Location

The location of park-and-ride facilities in relation to the city center depends upon topographic features; traffic congestion and travel constraints; rapid transit route and station locations; and land type, density, availability, and costs (3). The following considerations should govern where park-and-ride facilities should be located:

1. **Locate in advance of congestion.** Park-and-ride facilities in combination with rapid transit lines generate the greatest use (and transit ridership) in travel corridors with the most intense traffic congestion (i.e., peak hour peak-direction freeway speeds of less than 30 to 35 miles per hour).  
Park-and-ride facilities should intercept motorists in advance of congestion and before points of major route convergence. Sites near junctions of radial transit lines and circumferential expressways or major arterial roads can tap a wide catchment area. Access should be upstream of major congestion points. An example is the large parking garage where Route 128/I-95 crosses the AMTRAK/MBTA Station in suburban Boston.
2. **Locate sufficient distance away from the city center.** Park-and-ride facilities should be located as far from the downtown area as practical to remove the maximum number of travelers (and VMT) from roadways during peak periods. They generally should be located at least 5 to 8 miles from the city center. They should be far enough away to compensate for the time spent changing travel modes. Increasing parking space on the fringes of the downtown area is not desirable since it could divert existing rapid transit riders from feeder transit service and non-motorized modes.

3. **Serve low-density residential areas.** Generally population densities in park-and-ride catchment areas should be less than 4,000 to 6,000 persons per square mile or about 4 to 5 dwelling units per net acre.
4. **Serve multiple markets.** Most rapid transit park-and-ride sites serve downtown travelers. However, there is a growing tendency to also serve other large activity centers along the rapid transit lines. The sites should be located between their catchment areas and major activity centers. Motorists will use facilities that can be easily accessed en route; but they are less likely to backtrack.
5. **Locate in safe areas.** Sites should be placed in areas that are perceived as safe by patrons. They should not be located in high-crime areas, or in settings that are considered unattractive by users.
6. **Complement and reinforce land development.** Park-and-ride facilities should be compatible with the surrounding environments. They should generally be placed in low-density areas. Large facilities—especially open-lot parking—should be limited or avoided in town centers, areas of high population and development density, and locations where transit-supportive uses are planned or encouraged around stations. Where garages are built, they should be carefully integrated with their surroundings.
7. **Provide fast and frequent rapid transit service.** Light and heavy rail rapid transit should operate at frequencies of 10 to 12 minutes or less during peak periods, while service frequencies up to 20 minutes are acceptable during midday hours. Headways of 20 to 30 minutes are acceptable for commuter rail service during commute hours.
8. **Provide good roadway access.** Facilities should be accessible and visible from nearby freeways and arterial roadways.

Exhibit 10-7 gives some characteristics of reported “successful” parking lots along rail and BRT lines. The park-and-ride lots are generally located at least 10 miles from the CBD and most are fully occupied on weekdays.

## Site Selection

Potential park-and-ride sites at a given rapid transit station should be evaluated in terms of availability, accessibility, visibility, physical feasibility, land use impacts, environmental compatibility, and development costs. Field surveys, analysis of aerial photography, and feedback from community stakeholders will be helpful in assessing and selecting specific sites.

### *Land Use Compatibility*

Sites should be compatible with adjacent land uses and they should not adversely impact nearby areas. They should achieve a reasonable level of usage relative to development costs. Site selection should give priority (in order of importance) to: (1) land currently in parking use; (2) undeveloped or unused land in public ownership; (3) undeveloped private land; and (4) developed private land. Every effort should be made to place facilities where they will be acceptable to neighboring areas; they should avoid environmentally sensitive areas.

Large park-and-ride facilities generally should not be located in or near town centers or other major activity nodes, or in densely developed areas. This guideline allows high-density, TOD clusters at selected transit stops; separates commuter and local parking demands; and reduces development costs and station impacts.

Sites should be of suitable size and shape to permit efficient design of access, parking, and passenger transfer facilities. Irregular or triangular sites should be avoided. Sites should be flat and well-drained so that grading, paving, and drainage can be provided at minimum expense. Soil should be able to support parking lot (or garage) construction. Difficult topography

**Exhibit 10-7. Characteristics of some successful park-and-ride facilities.**

Urban Area		Dallas, TX	Miami, FL	Philadelphia, PA	Pittsburgh, PA
System Facility		DART	Miami-Dade, Trirail	SEPTA	Port Auth. of Allegheny Co
		Mockingbird	Golden Glades	Cornwells Heights	South Hills Village
Distance (miles) from:	CBD	3	12	14	11
	Urban Edge	25	4	6	15
	Highway	0.3	0.1	0.2	3
Transit Service	Mode <sup>a</sup>	LRT, arterial bus	Commuter Rail, freeway HOV lane & arterial bus	Commuter Rail	LRT
	Frequency <sup>b</sup>	5	5	15	6
Park-and-Ride Lot Amenities <sup>c</sup>		S, L, K, B	S, L, G, K	S, L, G, R	S, L, G, K, B
Lot Capacity – Spaces		750	n/a	1,600	1,000
Weekday Occupancy		750	750	725	1,000
Other Corridor P&R Parking <sup>d</sup>		3,000	None	922	2,200

<sup>a</sup> LRT = Light Rail Transit.

<sup>b</sup> Peak period “frequency of transit” serving park-and-ride lot in minutes.

<sup>c</sup> S=shelter, L=lighting, G = security guard, K=kiss-and-ride “drop-off” spaces, R = Restrooms, B = bicycle racks.

<sup>d</sup> Total number of cars parked at other park-and-ride lots in the same corridor.

Source: *Urban Transportation Monitor (59)*

should be avoided. Sites should also be large enough to provide the desired number of parking spaces.

**Safety and Security Considerations**

Sites should be visible from approach roads. They should be selected, designed, and developed to allow convenient visual monitoring and to maximize security. Good pedestrian visibility is essential.

Sites should have adequate frontage so that access points onto public roadways can be placed away from signalized intersections.

Sites should be located in areas that are perceived as safe by users. Safety should be enhanced by providing illumination, eliminating obstacles to visibility, and providing emergency communications.

**Facility Size**

The size of a park-and-ride facility depends on estimated parking demands, transit service frequencies, street system capacity, availability of reasonably priced land, and environmental



constraints. In general, more space is needed in low-density suburban areas where there is very little feeder bus or pedestrian traffic. Conversely, where space is limited, priority should be given to providing space for persons with disabilities, passenger drop-off (kiss-and-ride), and short-term parking for drivers waiting to pick-up passengers.

Unduly large or small facilities generally should be avoided. Small lots will not provide enough space to justify frequent rapid transit service and may result in issues with spillover parking. Very large facilities may result in long walk distances, or underutilization which would be a poor use of funds and tend to create a negative image of the transit system. Suggested size ranges are as follows:

- BRT park-and-ride lots do not need to be very large. Even small shared use lots sometimes work in the right setting. Generally lots should contain at least 250 spaces. An optimum size range is 400 to 700 spaces, although this will vary depending on demand.
- Commuter rail and heavy rail transit facilities usually range from 500 to more than 2,500 spaces. In a few cases, lots and garages are larger. These facilities support frequent transit service and draw patrons from a large catchment area. Larger garages and lots may require a grade-separated access road system or involve very long walking distances. They may create congestion on approach roads.
- To accommodate daily fluctuations in park-and-ride demand, stations should not average more than 95 percent occupancy over a typical month period wherever possible, to minimize impacts of spillover parking. A design use factor of 80 percent is desirable to allow for long-term growth at the station. Growth could be in the form of additional park-and-ride spaces, increased space for bus bays and shuttles, bicycle parking, or other uses. Spillover parking effects from excess demand can have negative impacts on the surrounding neighborhood.
- Facilities should prioritize passenger drop-off and pick-up and handicapped parking. This is especially important for facilities with less than 250 spaces serving rail transit lines.

## Facility Types and Costs

The choice of parking facility—open-lot parking or parking garage (structure) near rapid transit stations—normally depends upon land availability and cost, parking demands and facility capacity, opportunities for multi-use TODs, and environmental effects.

### *Facility Types*

Parking lots are usually preferable where physical and environmental conditions permit. However, parking structures may be necessary under the following circumstances:

- Open-lot parking space is insufficient to meet the anticipated park-and-ride demands and the available land for additional parking is insufficient to meet the demand.
- Walking distances between the station entrances and the most remote parking spaces exceed about 600 feet.
- The parking footprint must be limited for environmental or land availability reasons.
- TOD is planned (or anticipated) adjacent to the station.
- Land costs are high and a parking structure would be less expensive in terms of life cycle costs.

### *Facility Costs*

Development costs for park-and-ride facilities should be kept to a minimum. Open-lot parking is generally less costly than garages. However, when land costs exceed about \$50 per square foot, multi-level garages may be less costly.

The development and operating costs of parking lots and structures were compared based on current operating experience. Typical unit costs for parking lots and structures are shown in

**Exhibit 10-8. Typical unit costs for parking lot and garages (2010 costs).**

	Surface Lot	Structured Garage	Underground Garage
Land	Costs range from \$10 - \$100+ per square foot or \$3,500 - \$35,000 per space.		
Construction	\$12 – 15 per square foot or \$4,200 – 5,250 per space.	\$14,000 per space for decks \$17,000 per space for multi-level garages	\$35,000 per space

Source: Adapted from *Transportation Planning Handbook, 3rd Edition* (30)

Exhibit 10-8. These costs are based on values cited in the ITE *Transportation Planning Handbook*, updated to 2010 (27). They assume 350 square feet per car.

The effects of land and construction costs (exclusive of design, interest, and finance costs) are shown in Exhibit 10-9. For land values below \$40 to \$50 per square foot, surface parking lots are more economical than structures. Where land costs exceed about \$100 per square foot, underground parking may be more economical than a surface lot. The specific lot versus garage trade-off points are provided in Exhibit 10-10.

Note that while Exhibit 10-9 indicates that a 7-story structure is always most cost-efficient that a shorter structure, this will depend in reality on the total size of the facility. A taller structure built for a small number of vehicles will have a higher portion of floor space used for parking aisles and ramps, limiting the efficiency of building taller structures for small park-and-ride facilities.

These trade-offs represent one point in time, and will change depending upon relative changes in lot and garage construction costs over time. In 1989, for example, the trade-offs between surface and structured parking ranged from \$25 to \$30 per square foot of land costs (42).

**Annual Cost Comparisons**

The comparative total annual costs for garages and lots provide additional guidelines. Development costs include land costs, design and construction costs, financing costs, and annual average debt service costs. Annual operating costs are then added to the debt service costs.

**Exhibit 10-9. Effects of land value on type of parking space (2010 costs).**

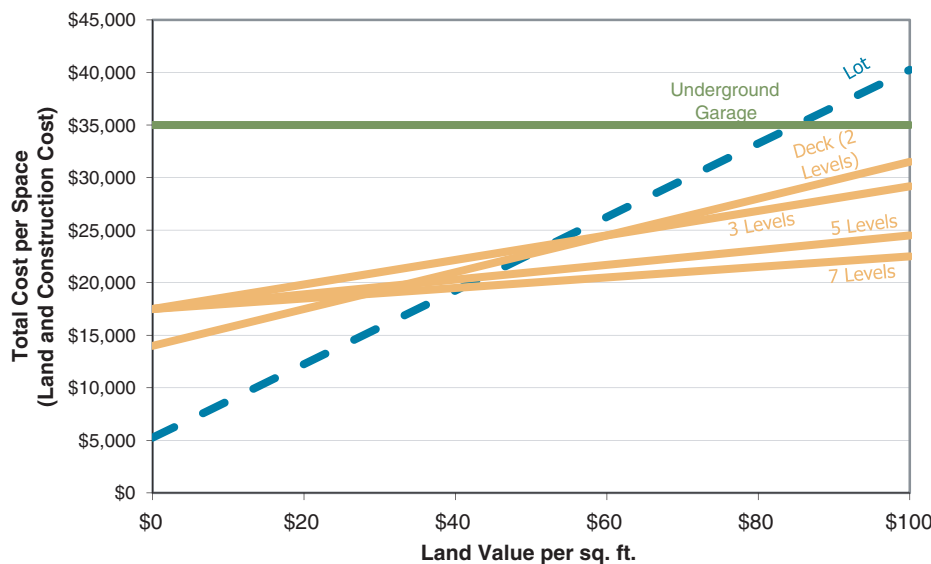

**Exhibit 10-10. Land cost breakpoints for parking facility construction.**

Facility	Break-even Land Cost (dollars/sq. foot)
Surface Lot	50
2 Level garage	70
3 Level garage	52
4 Level garage	44
5 Level garage	42
7 Level garage	39
Below ground garage	85

**Source:** Computed

The detailed steps are as follows:

1. Land costs per space are pro-rated based upon the number of levels.
2. A 15% engineering design cost is added to the construction cost per space.
3. The total development costs per space (1 and 2) are increased another 15% to reflect financing costs (e.g., interest during construction period).
4. The annual development costs depend on the anticipated life of the facility (e.g., 25 years) and the likely interest rate (5 percent). Calculations assume a 0.07 capital recovery factor. This factor was applied to obtain an estimate of the annual costs.
5. Annual operating costs per space were assumed as \$600 per space for garages and \$200 per space for lots. These values are suggested in the ITE *Transportation Planning Handbook* (the annual difference in operating cost was \$400 per space).

A second set of computations were performed based upon values used by the BART District; these values were \$540/space/year for garages and \$350/space for lots, a difference of \$190 per space.

6. Computations were performed for surface lots, and 3-, 5-, and 7-level garages. The analysis equated the total annual lot and garage costs from which the break-even land costs were obtained. The resulting costs were divided by 350 to obtain the costs per square foot.

The resulting analyses are shown in Exhibit 10-11. The minimum land costs needed for parking structures (including debt service) range from \$55 per square foot for 7-level garages to \$94–\$100 per square foot for 2-level garages (i.e., parking decks).

### ***Space Demand Estimates***

The amount of parking space that should be provided at any given location depends on its traffic potentials, street system capabilities, compatibility with adjacent land use, and the location of reasonably priced land. More parking space is generally needed in low-density suburban areas where pedestrian and feeder bus traffic is minimal. Where space is limited, priority should be given to kiss-and-ride patrons. End-of-line stations typically have larger catchment areas and need more parking.

Outlying parking potentials should clearly recognize CBD growth patterns, constraints to increasing CBD parking supply, extension of rapid transit services into auto-oriented areas, and rapid transit ridership. Park-and-ride demand is inversely proportional to transit service levels within the market area, and the level of connectivity to the bus network. Station parking could begin as unpaid and transition to paid parking as needed to meter demand.

Park-and-ride space requirements should be estimated for (1) the opening year, (2) a year when parking space usage and ridership has reached its potential (usually three to five years into the future), and (3) the design year (usually 20 years into the future).

**Exhibit 10-11. Minimum land costs for structured parking based on annual development and operating costs (2010 conditions).**

Number of Garage Levels	Minimum Land Cost (Dollars per sq. ft.)		
	A	B	C
2	\$100	\$94	\$70
3	\$82	\$70	\$52
5	\$68	\$59	\$44
7	\$64	\$55	\$42
Difference between Lot Garage and Annual Operating Costs per Space			
A	\$400	(ITE Data)	
B	\$190	(BARTD Data)	
C	\$0	Capital Cost Only (no adjustments for design and finance)	

Source: Computed

Generally, the space supply should exceed the peak occupancy by about 10 percent and peak demand should not exceed 90 percent of the available space. Terminal or near terminal stations along heavy rail and light rail transit lines should provide about 25 percent more spaces, if space permits, than initially required to better prepare for untapped potential demand.

Estimating demand for the number of park-and-ride spaces (and boarding passengers) at any given station can be done in several ways:

- Analogy with similar conditions within a given urban area or in other areas.
- Targeted surveys of residents within an influence area of a station. Most patrons come from within a few miles of a station. However, terminal rail rapid transit stations may attract riders from distances of up to about 20 miles to take advantage of faster overall travel times, and potentially lower fares and more frequent service. Catchment areas are usually elliptical with the greatest pull from the outbound side.
- Using observed relationships between the number of boardings and the number of park-and-riders. Generally there are between 0.4 and 0.6 parking spaces per boarding passenger at stations along rail transit lines in suburbs.
- Using the station access model described in Chapter 5.

Typically, about 2 to 6 percent of all parking spaces should be allocated to short-term parking for passenger drop-off and pick-up (i.e., kiss-and-ride).

## Traffic and Parking Management Guidelines

The following operations and management guidelines will prove useful in improving automobile access to, from, and within park-and-ride facilities.

### Passenger Drop-offs and Pick-ups

Passenger drop-offs and pick-ups should be located to avoid conflicts with bus, auto, and pedestrian movements in the station area.

- Locate drop-off areas and taxi stands as close as practical to the station entrance without interfering with feeder bus operations, which typically have higher priority.

- Clearly mark zones for taxis and drop-off/pick-up activity.
- Locate drop-off and pick-up areas to improve safety and minimize congestion impacts. Drivers should be able to stop without impeding traffic flow or delaying transit vehicles.
- Provide space for ADA parkers.
- Pedestrian areas should be designed with enough space to accommodate passengers waiting to be picked up, with lighting, seating, and weather protection. It may be possible to combine bus and drop-off waiting areas, providing that automobiles do not delay buses.
- Optionally provide reserved space for midday riders.

### **Guidelines for Various Users**

Parking should be located for different users in accord with each access mode's space requirements:

- Locate carpool and motorcycle parking closer to the station entrance than parking for other users. In garages, carpool and motorcycle parking should be located on the first or second floors.
- Reserved spaces for car sharing services should be located in high-profile locations, in areas that are closer to station entrances than most of the at-large parking spaces.
- No park-and-ride space should be located more than ¼ mile from the station entrance wherever possible.
- Design parking to be shared with other users, where appropriate. For example, residential or entertainment uses may be able to use station parking on evenings and weekends.
- Pedestrian pathways through parking facilities should be clearly indicated with sidewalks or surface markings.
- Design parking access and egress routes to minimize traffic impacts on the surrounding local transportation network.

### **Facility Arrangement and Design**

The design of park-and-ride facilities should be keyed to the surrounding environment. Consideration should be given to neighborhood character, facility demand, distance from the city center, and the needs of motor vehicles, transit users, and pedestrians. Illustrative design guidelines are shown in Exhibit 10-12.

### **General Considerations**

The parking space layout generally should be similar to that for other parking facilities. However, facilities must (1) accommodate transfers between automobiles and rapid transit; (2) provide short-term as well as long-term parking and passenger loading areas; and (3) handle most traffic in two short peak periods daily.

The bus passenger loading area should be the focal point of pedestrian access. It should be located adjacent to or over the station platforms. There should be convenient, conflict-free pedestrian interchange to, from, and between bus stops, parking facilities, and the station entrance. Internal circulation patterns should separate bus transit, drop-off patrons, and park-and-ride users.

### **Access Concepts and Geometry**

Access design and location are normally governed by topography, available site frontage, and the types and locations of surrounding roads and connecting transit services. They

**Exhibit 10-12. Design guidelines for park-and-ride facilities.**

<b>Design Element</b>	<b>Guidelines</b>
Distance from activity center served (minimum)	5-8 miles
Maximum size	
Lot (typical)	900 – 1,200 spaces
Garage (typical)	1,200 – 1,500 spaces
Parking spaces per acre	125 – 135
Square feet per space	400 – 425
Location of bus loading area	On-street or within lot
Separate bus access	
Less than 350 spaces	Optional
More than 350 spaces	Yes
Maximum passenger accumulation/shelter	80 – 150 people
Bus loading berths (typical)	1 to 4
Maximum desirable pedestrian walking distance	1,200 feet
Kiss-and-ride spaces (percent of total spaces)	2 – 6%
Peaking characteristics	
Peak hour directional movement as a percent of daily traffic	30 – 40%
Peak 15 minutes as a percent of peak hours	30%

**Source:** H.S. Levinson, adapted from various sources

should permit easy maneuverability for both autos and transit vehicles, and maximize safety. They should be integrated with the approach and boundary system. Major circulation routes should be located on the periphery of the parking areas to minimize vehicle-pedestrian conflicts.

1. Circulation patterns should be clear and consistent; drivers should be confronted with only one decision at any given time.
2. The capacity of ingress and egress points should be adequate.
3. Sufficient queue storage space should be provided on parking access roads.
4. Transit vehicles should have physically separated roadways and should not be required to use parking lanes.
5. Turning radii are typically governed by bus turning geometry.
6. Parking aisles should be oriented so pedestrians can use them to reach the rapid transit station.

Access ramps and roadways that connect park-and-ride facilities to major commuter routes should avoid excessive interruptions from traffic signals, curb parking interferences, or frequent commercial curb cuts. Grade-separated access to major facilities may be desirable, such as found in the Houston, Boston, and Washington, D.C., areas.

Access routes should be related to principal patron directions of approach. When practical, park-and-ride traffic should be evenly distributed over boundary routes and should not be unduly concentrated on a single approach direction.

When a choice readily exists, it may be desirable for the park-and-ride lot to be located on the right side for signalized inbound traffic to eliminate the need for left-turn entering movements.

Access drives located on the left side of a two-way arterial roadway for left-turn storage lanes should provide for vehicles entering the parking facility.

Parking entrances and exit locations should avoid spillback from nearby freeway interchanges or intersections. They should be set back at least 150 feet (preferably 250 feet) from nearby intersections and spaced at least 350 feet apart. Access points directly opposite freeway ramps or near signalized intersections should be discouraged.

Access points should be placed where park-and-ride traffic does not filter through built-up residential neighborhoods or commercial areas.

At least two combined entrances and exits should be provided for facilities with more than 500 spaces. Multi-lane access points and separation of entering and exiting traffic is desirable, especially where facilities exceed 500 spaces. Roadway design and traffic management plans should accommodate peak surges. (About 40 percent of the daily traffic entering a transit park-and-ride site occurs in the facility's peak hour and 30 percent of the peak hour traffic enters in the peak 15 minutes.)

One-way entrance and exits can simplify pedestrian crossings along boundary roads and streets.

Traffic engineering analysis should identify where acceleration, deceleration, and turning lanes should be provided at large facilities. They should be installed as specified in the *Manual on Uniform Traffic Control Devices* and coordinated with nearby traffic signals.

Directional and informational signs along major highway routes leading to the park-and-ride facility should make it easy to reach. Internal signage should delineate commuter parking passenger drop-off and pick-up areas and bus passenger loading areas.

## Facility Arrangement

The internal site design should minimize walking distance to rapid transit stations. The following location priorities are suggested in terms of proximity to the station: (1) bus loading/unloading (when buses use access to park-and-ride); (2) taxi loading/unloading (may mix with buses or cars) (see Exhibit 10-13); (3) handicapped parking; (4) passenger drop-off and pick-up

**Exhibit 10-13. Taxi loading area (Metropark, NJ).**



Source: Kittelson & Associates, Inc.

**Exhibit 10-14. Park-and-ride integrated with rapid transit station (New Carrollton, Maryland).**

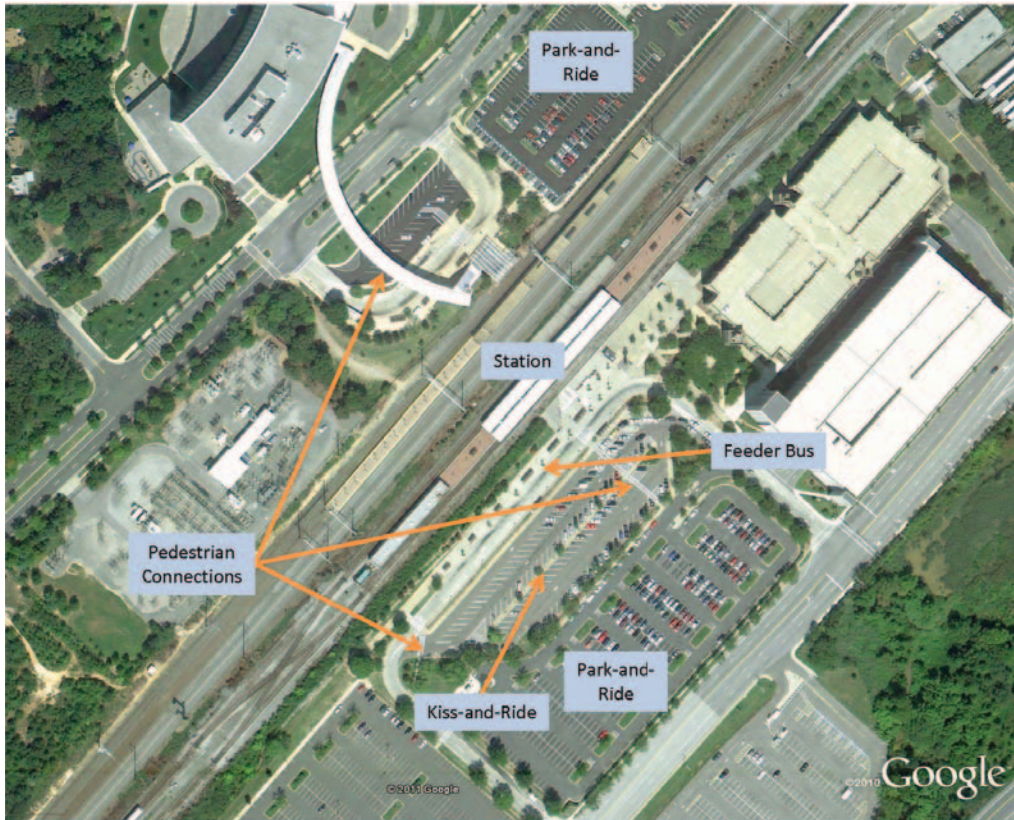

Source: © 2011 Google

(kiss-and-ride); (5) bicycle and motorcycle parking; (6) short-term parking; and (7) long-term parking (Exhibit 10-14).

Exhibit 10-14 shows how park-and-ride facilities can be arranged to give priority access to buses, taxis, and kiss-and-ride patrons. Parking is oriented to enable parkers to use parking aisles as walkways to reach the transit terminal. Entrance and exit points are separated to simplify traffic controls and vehicle routings, and to minimize pedestrian conflicts.

### Bus Access

Bus access to rapid transit station entrances and platforms can be provided in several ways. Buses can use access drives to parking spaces to reach the station entrances. This works where there are less than 350–500 spaces. At larger park-and-ride facilities, buses should have separate roadways to reach station entrances.

Many transit agencies provide separate areas for bus access, kiss-and-ride, and park-and-ride. Facilities are clustered around the rapid transit station entrance. An illustrative example is shown in Exhibit 10-15. Where park-and-ride spaces are provided in parking structures, bus access is usually provided around the perimeter of the structure (Exhibit 10-16).

Bus roadways should permit passing stopped or standing buses. Buses should not be required to back up within station areas.



**Exhibit 10-15. Park-and-ride lot separated from bus loading and transit platform access (Willowdale, Ontario).**



Source: © 2011 Google

**Exhibit 10-16. Bus access around parking structure (Cambridge, Massachusetts).**



Source: © 2011 Google

Connecting bus service determines many design dimensions. Key design considerations include minimum lateral and vertical clearances and provision of adequate turning radii, roadway widths, and sight distances. Chapter 9 provides more detailed guidance on bus access to rapid transit stations. Bus terminals can also be incorporated into, or on the perimeter of, large parking garages.

## Kiss-and-Ride

Kiss-and-ride facilities (Exhibit 10-17) should be provided wherever possible. These facilities at rapid transit stations typically include areas used for dropping-off and picking-up transit passengers, as well as taxi stands and provisions for paratransit vehicles and private shuttle buses. It may be possible to combine kiss-and-ride and transit areas provided that automobiles not delay transit vehicles (60).

Kiss-and-ride facilities should be designed to maximize vehicle turnover, facilitate traffic circulation, and minimize conflicts between vehicles and pedestrians. One-way traffic flow is desirable, and the site access plan should permit vehicles to recirculate.

All stations, whether or not they have park-and-ride facilities, should provide kiss-and-ride where practicable, sized to meet forecast or demonstrated demand. Denver RTD suggests that stations located in TOD areas could be accommodated by on-street kiss-and-ride facilities, subject to the review of local jurisdictions.

- Except where prevented by physical site constraints, the kiss-and-ride should not exceed 400 feet walking distance from the platform center.
- The kiss-and-ride should have a direct line-of-sight to the station entrance.
- Pedestrian crossings from the drop-off/pick-up lane should include a stop sign and marked crosswalk.
- Signage should direct both vehicles and passengers exiting stations to the drop-off/pick-up area.
- The parking spaces for vehicles waiting to pick-up passengers should be conveniently located and visible to the passenger pick-up area.
- Pavement should have a maximum 3% cross slope.

**Exhibit 10-17. Kiss-and-ride area (Seattle).**



**Source:** Kittelson & Associates, Inc.

- About 7 to 8 minutes time per vehicle is needed on average during the P.M. peak period for vehicles waiting to pick-up waiting passengers.
- Taxis should be provided with a separate loading area.

### Station Pedestrian Circulation

Safe and convenient pedestrian access from adjacent streets and from within the park-and-ride facilities is essential. Walking paths should be direct (see Exhibit 10-18). Ideally, distances from parking space to the rapid transit station should be less than 600 feet; distances should never exceed  $\frac{1}{4}$  mile.

Parking aisles should be oriented toward the transit boarding area to shorten walking distances and facilitate walking. Special walkways should be provided, at least 5 feet wide. At the rapid transit station entrance, walking and waiting areas should be at least 12 feet wide.

The coefficient of directness (ratio of actual length of walking path to the airline distance) should not exceed 1.2 to 1.4.

Parking spaces should be as close to the passenger station platforms as possible. Denver RTD specifies that at least half of the parking spaces be located within 600 feet of the station platforms and that all spaces be located within 1,500 feet (air distances). These figures translate into maximum walking distances of 840 and 2,100 feet, respectively (60).

**Exhibit 10-18. Direct and open connection to transit station (Englewood, Colorado).**



Source: Kittelson & Associates, Inc.

## Parking Dimensions

Suggested unit dimensions (2 spaces plus one aisle) should be at least 60 to 65 feet for 90 degree, long-term parking and at least 62 to 63 feet for short-term parking and passenger drop-off or pick-up. An 8.5-foot stall width should be provided for all-day parking and a 9-foot width for short-term parking or passenger drop-off to accommodate all vehicle types. Eight-foot stall widths are sometimes used for all-day surface parking.

However, flexibility in design is encouraged to allow for maximum efficiency in transit facility use. Either 90-degree or angle parking can be used. Right-angle (90-degree) parking usually gives the most efficient space configuration; it allows two-way traffic flow in aisles and is the simplest pattern to recognize. However, there may be specific cases where angle or even parallel parking may be appropriate.

Typical parking module (i.e., two spaces plus one aisle) widths based on 9-foot-wide stalls are as follows:

- 45 degrees, 45 feet
- 60 degrees, 53 feet
- 75 degrees, 61 feet
- 90 degrees, 63 feet

Bus parking stalls should be at least 13 by 42 feet for 40-foot buses and 13 by 65 feet for 60-foot articulated buses.

Grades on parking areas should allow effective drainage. They should be at least one percent; however, 2 percent is desirable with a maximum of 5 percent. Excessive grades of more than 8 percent parallel to the auto should be avoided. If this is not possible, the parking layout should be rotated 90 degrees, or curbs and wheel stops should be provided.

## Operations and Maintenance

Some key operations and maintenance guidelines follow.

### Hours and Use

Park-and-ride facilities are usually open either 24 hours or, alternatively, just during the hours that the rapid transit service operates (e.g., 5 a.m. to midnight). Some spaces may be designated for short-term parkers and located in a separate area. Gating or control is necessary where parking fees are collected and where facilities are sometimes closed.

### Pricing Policies

Park-and-ride facilities along rapid transit lines sometimes charge parkers, especially where facilities experience strong demand. Rates are substantially less than all-day downtown parking charges.

As a general guide, the parking fees in combination with the round trip transit fare should be less than all-day parking costs in the CBD.

Fees may be set on a daily or monthly basis or they may be tied to the length of time parked. When fees are charged on a variable hour basis, motorists receive a ticket upon entry and pay when they leave; the fee schedule should be simple and clearly posted at the lot entrance (Exhibit 10-19). When fees are paid on a daily or monthly basis, they may be paid upon entry or exit. Exiting

**Exhibit 10-19. Parking fee schedule at park-and-ride entrance (Metropark, NJ).**



**Source:** Kittelson & Associates, Inc.

movements from park-and-ride facilities are often keyed to train arrivals; there are sharp surges in demand for relatively short periods of time. A sufficient number of exit lanes and attendants is necessary to avoid long queues and wait times.

Some park-and-ride facilities (e.g., BART and Miami) use a system of numbered parking spaces, where riders pay for and register their space inside the station itself. This means of charging for parking helps to ensure that parking is used only by transit riders.

# TOD and Station Access

Land development considerations are an essential part of station access and design. Development opportunities depend on station location, the character of surrounding areas, and market potential. Thus, they may vary along any given rapid transit line.

Also important are planning and zoning requirements, cooperative working arrangements between transit agencies and local planning groups, and the presence of planning and policy guidelines.

This chapter presents the salient issues and opportunities, with a focus on TOD. It describes land development around stations, presents general guidelines, describes and analyzes the trade-offs between TOD and station parking, and suggests possible directions for existing and proposed systems.

TOD can be defined as the planning and design of a mix of medium- or high-density land uses around a transit station that serves as the focal point of the development. Its goals are to better integrate the transit system with the surrounding community (as in Exhibit 11-1), increase transit ridership, and enhance non-motorized access to transit. It is not highway-oriented development that just happens to be close to stations; diversity and walkability are essential.

TOD has several important advantages:

- It can make the transit station environment more cohesive with the surrounding areas.
- It generates fewer motor vehicle trips per unit of development, compared with similar uses located elsewhere (19).
- Under specific circumstances, it can reduce the development's parking demand by up to 50 percent, compared with similar uses elsewhere (21).

## Issues and Opportunities

Planning for TOD is perhaps the most complex aspect of station planning because it involves several different entities with widely differing interests. Beyond the transit agency, it includes local governments, the local community, and private developers.

Three critical and inter-related issues regarding TOD emerged from the case studies conducted at BART (San Francisco), Los Angeles Metro, MARTA (Atlanta), MBTA (Boston), Metro-North (New York), New Jersey Transit, OC Transpo (Ottawa), and RTD (Denver). These issues were: (1) balancing parking needs and locations with developer expectations (actually or apparently driven by market factors); (2) financing the TOD, particularly parking, to meet the needs of both commuters and private developers; and (3) neighborhood concerns about the TOD, its potential residents, and potential problems with spillover parking.

**Exhibit 11-1. Example of station design integrated into the surrounding community (Englewood RTD Station, Denver).**



**Source:** Kittelson & Associates, Inc.

Parking is a persistent issue because TOD projects commonly displace existing surface parking. TOD typically is placed where there is already high market demand (which makes TOD viable), and parking is therefore scarce. Since the park-and-ride spaces were present before the TOD project, and commuter habits have already been formed, a reduction in station parking can lead to spillover parking problems. Transit agency station access guidelines or policies usually require “one-for-one” replacement of lost parking, and when there are constraints on available nearby land or funding, the identified solution is usually a more costly parking structure (Exhibit 11-2).

In such cases, the transit agency should explore trade-offs to find ways to make TOD work. Some flexibility in parking replacement guidelines or policies may lead to successful compromises. Precise one-for-one replacement may be unnecessary: where rapid transit services are competitive in terms of quality and capacity, it has sometimes been possible to convert park-and-ride travelers to bus access, either directly or through a remote parking facility. TOD parking should generally be limited, and parking pricing can also be considered for added leverage.

The access planning tool developed with this guidebook assists in weighing the trade-offs between parking and TOD, including evaluating impacts of parking pricing. Appendix C provides detailed instructions on using the access planning tool.

Some transit agencies have addressed parking constraints by subsidizing the cost of parking structures to make projects feasible for private developers. Funding through California’s Proposition 1C has made this possible for BART and LA Metro. NJ Transit and other agencies have also funded the construction of parking structures to make TOD feasible for developers. Whether this approach can be followed elsewhere depends on the availability of funds and the cost-effectiveness of “buying” TOD with subsidized parking infrastructure. These will necessarily be local decisions.

Transit agencies with active joint development programs (LA Metro, BART, and WMATA among the case studies analyzed for this research) have found that agency-wide joint development policies can benefit negotiating solutions that help achieve agency goals. These policies define

**Exhibit 11-2. Parking structure at a rapid transit station (Sierra Madre Metro Station, Los Angeles).**



**Source:** Kittelson & Associates, Inc.

development requirements and procedures, and provide criteria for evaluating competing development proposals.

Neighborhood concerns about TOD can include resistance to changes in density, along with concerns about spillover traffic and parking and an influx of new, perhaps different, neighbors. These can be complex issues, but they have been addressed through the planning process with outreach, collaborative planning, and design adaptations and, in some cases, community-based design charrettes in which community–agency teams identify problems and seek design and operating solutions for them.

These processes and financing actions, while they will not always work, offer the basis for making the trade-offs and compromises often necessary to implement TOD. The value of such actions can be assessed over the long run by tracking the implementation and operation of local TODs.

## **Development Types and Sizes**

The types and sizes of TOD in rapid transit station environs depend on many related factors. These factors include land size, shape, terrain, and costs; zoning requirements; market potential; transit ridership effects; and traffic and parking impacts. The basic types of land development are summarized in Exhibit 11-3 and consist of the following:

- At one end of the spectrum are activities that are located within the transit station, such as newsstands and eating establishments that draw their patrons from people traveling to



**Exhibit 11-3. Basic types of TOD.**

	<b>Commercial within Station</b>	<b>Commercial on Adjacent Streets</b>	<b>Residential Development</b>	<b>Commercial or Mixed-Use Development</b>	<b>Large Scale Mega-Center (or Town Center)</b>	<b>Central Business District</b>
Location	Within, above, or below station	Around station	Area surrounding station	Area adjacent to and surrounding station	Area adjacent to and surrounding station Town Center	City center and environs
Activities	Convenience retail Fast food establishments Office: above/below station	Convenience retail Eating establishments	Mainly trips to work/school Shop	GAF retail Office Some residential	Retail Office Residential	Retail Office Government Some residential
Examples	Grand Central Station, NY Metro-North New Haven Station, CT	Metro-North Westport Station, CT	Francisco Station, Brown Line, Chicago	Lenox Square, Atlanta	Central City, Los Angeles	Downtown Boston Downtown San Francisco
Transit Ridership	Mainly existing riders	Mainly existing riders	Some new riders	Some new riders, mainly from new residential areas	Could attract considerable new transit riders	Would attract considerable new transit riders
Traffic & Parking Impacts	Minimum	Minimum	Some, however residential parking can be removed from station parking	Could require garages to accommodate top patrons, likely increase in street traffic volume	Considerable, would need adequate development space and addition to parking supply	Considerable. Best strategy is to limit CBD employee parking expansion

or from trains. These activities generate few, if any, traffic, parking, or transit ridership impacts.

- Next in size are small convenience retail stores and eating establishments located along streets that front the transit station. In most cases, these activities also generate minimal impacts.
- Residential developments that are located near stations may generate rapid transit trips, especially where transit provides fast and frequent service to the city centers. Parking requirements are linked to non-work travel requirements, since the work trip is likely to be made by rapid transit.
- Retail and mixed-use developments around stations require parking space beyond that normally provided by park-and-ride facilities. A common practice is to increase the available parking space by building garages serving both development visitors and commuters. Increased traffic volumes usually call for roadway improvements. These developments can generate increased transit ridership and can also enhance the pedestrian environment for existing passengers (Exhibit 11-4 and Exhibit 11-5 show examples of development adjacent to rail stations).
- Large scale mega-center developments have the combined effects of increasing both transit ridership and parking. A planning challenge is making them both transit- and pedestrian-friendly.

**Exhibit 11-4. Commuter rail TOD (Kent, Washington).**



**Source:** Kittelson & Associates, Inc.

- At the other end of the TOD spectrum is the expansion and intensification of the city center and its environs. In these cases, pedestrian circulation and transit access should be encouraged. Parking, where provided, should be limited to short-term users.

### **TOD—Where Does It Work?**

TOD works best where there is a strong market and good transit agency and community support. It is generally viable where there is proximate medium to high residential development or where developable land is available (see Exhibit 11-6), and the TOD serves to integrate the community with the nearby rapid transit station.

**Exhibit 11-5. Example of pedestrian-friendly mixed-use TOD (Fruitvale BART Station, Oakland).**



**Source:** Kittelson & Associates, Inc.

**Exhibit 11-6. Under-utilized surface parking lot as development opportunity (Metropark, NJ).**



**Source:** Kittelson & Associates, Inc.

The number of TOD projects continues to increase. Some illustrated examples are shown in Exhibit 11-7. Further examples of TOD are found in many urban areas, such as San Francisco, Washington, D.C., and Atlanta, and include the following:

- Arlington, Virginia, where the Metro line runs in a subway, has adopted form-based zoning, with commercial zoning around rail stations. Rosslyn has emerged as a major center because of the excellent transit service and its proximity to Central Washington.
- Major stations in affluent areas such as Friendship Heights, Bethesda, and Silver Spring, Maryland, have attracted considerable development, including large retail stores.
- Atlanta's north corridor rail line, located alongside or within the Route 400 freeway, has major developments at several stations, including the Lindbergh Center, Medical Center, and North Spring stations.
- TriMet's Westside MAX light rail has attracted TOD at several stations, including Orenco Station and 185th Street.

## General Guidelines

Some guidelines and perspectives for TOD follow:

1. **Serve Strong Markets.** Viable markets are essential. Markets depend on population, the income and demographic characteristics of the likely catchment area, and the likely competition. Densely developed neighborhoods, especially within a ½-mile radius of rapid transit stations, can provide a good market. Some activities in TODs, however, will attract patrons from a large area by rail or by road.
2. **Reflect Community Objectives.** TOD in rapid transit station environs should reflect community goals and objectives. The sizes and types of development should be acceptable to the impacted community (see Exhibit 11-8).
3. **Provide Supportive Community Zoning.** Zoning policies for the station and its environs should support the planned development. "Station overlay" zones are one possible way to permit desired developments.

**Exhibit 11-7. Examples of mixed-use TOD projects.**

Location <sup>a</sup>	Development Mix	Situation	Travel Impact
Ballston Station Area Arlington, VA 1960-2002	5,914 residential units Office: 5,721,000 sf Retail: 840,000 sf Hotel: 430 rooms	The Ballston area has transformed from an automobile-oriented close-in suburb into a full-fledged TOD since the HRT Metrorail station opened in 1979, supported by strong planning. Retail activity in Ballston is bolstered by an enclosed destination shopping mall located within walking distance.	The walk mode share of access/egress for the station in 2002 was 67% of about 22,000 average daily entries plus exits. Case study, "Arlington County, Virginia, TOD Densities," provides additional findings.
Village Green Arlington Heights, IL 2001	250 condominiums Office: 17,000 sf Retail: 53,000 sf	The Village Green project is located in downtown Arlington Heights, near the commuter railroad station. A big grocery store is also within walking distance. One of several downtown redevelopment projects.	Of all downtown residents (inclusive of Village Green project), 17% report Metra as their primary commute mode, versus 7% for all of Arlington Heights.
Mockingbird Station Dallas, TX 2000	211 apartments Office: 140,000 sf Retail: 180,000 sf <sup>b</sup>	This \$105 million project is located on a 10-acre site 4 miles from the CBD via LRT, adjacent to SMU and the North Central Expressway. A full service grocery store is within 5 minutes on foot.	Parking requirement reduction of 27% was allowed for shared use parking. About 10% of patrons are reported to arrive by transit.
Hazard Center San Diego, CA 1997	120 condominiums Office: 300,000 sf Retail: 136,000 sf Hotel: 300 rooms	Constructed on formerly industrial land, this development on the Mission Valley LRT line has gradually grown into a horizontally mixed, mixed-use center. Pedestrian-friendly design encourages living, working, and shopping within the self-contained community.	No quantitative travel data given. The supermarket has been observed to serve customers from other rail stations.

Notes: <sup>a</sup> Date(s) indicate time of implementation for the development mix indicated.

<sup>b</sup> Figure includes retail, restaurants, and entertainment uses.

sf = square feet.

Source: *TCRP Report 102 (22)*

4. **Transit Agency Initiatives.** Transit agencies should take the initiative. The Denver RTD suggests preparing a strategic plan for TOD. This plan should be visible and continuously updated. The policies should form an integral part of the station design process (23). These policies define development requirements and procedures, and provide criteria for evaluating competing development proposals.

Several North American transit agencies have begun to act as developers, financing and organizing developments around their stations. TriMet in Portland, Oregon, for example, partnered with the Portland Development Commission to develop a 3-acre site for a 100,000-square-foot medical office building that was built along the Red and Blue Max Lines (24) and that includes both station area plazas.

5. **Advance Property Acquisition.** Land in the environs of stations should be acquired by transit agencies once the rapid transit alignment is finalized. This is especially important along extensions of both existing and new services. It will make the land readily available

**Exhibit 11-8. TOD integrated into community revitalization (Rahway, NJ).**

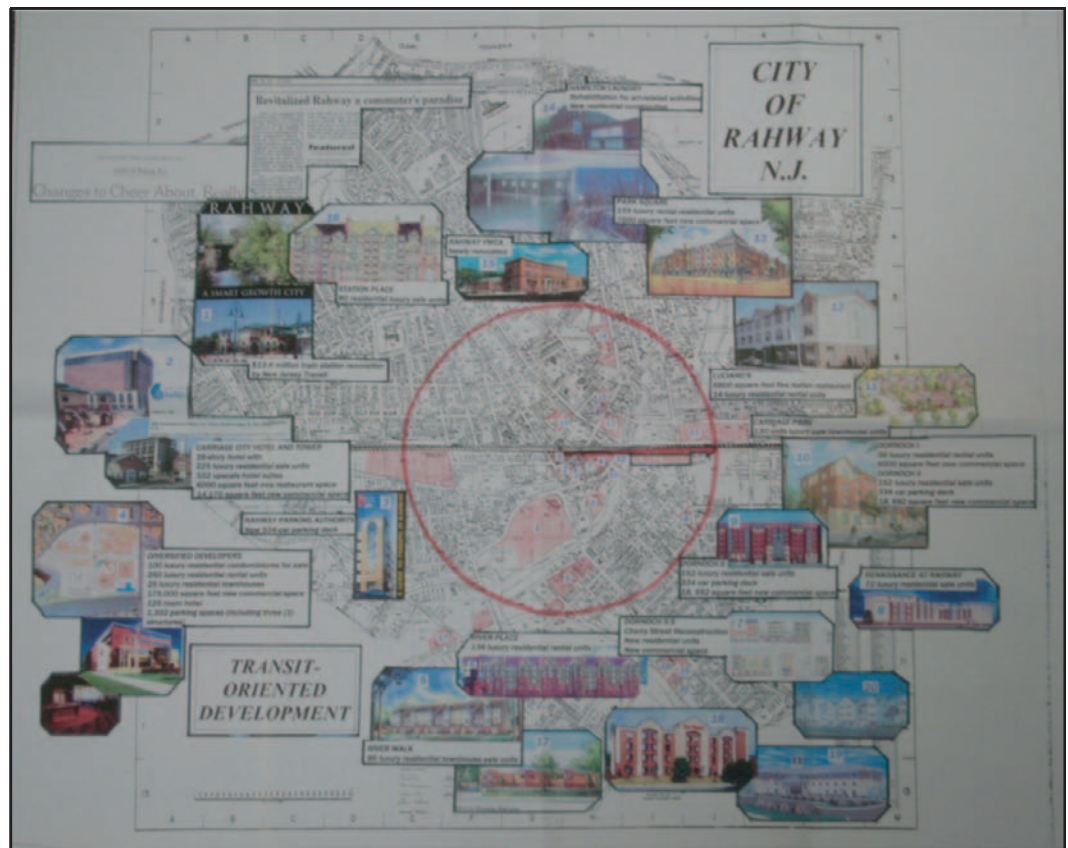

Source: NJ Transit

for development before the line is built and opened for revenue service. It allows timely construction of TOD.

6. **Focus on Maximizing Ridership.** Transit and planning agencies should encourage land uses that will contribute to rapid transit ridership. Examples of such uses include residential developments and large office complexes that are clustered around stations. BART found that transit will capture over 40 percent of residential work trips. Exhibit 11-9 illustrates the transit capture assumptions by trip type at BART.
7. **Provide Developments Instead of Parking.** There are certain situations where TOD should be considered as an alternative to providing parking. These locations include: (1) the city

**Exhibit 11-9. Example TOD transit capture by trip type.**

Development type	Trip type	Trip type split (%)	Percent transit capture (%)
Residential	Residential work	25	40.5
	Residential non-work	75	8.55
Retail	All	100	11.7
Medical Office	All	100	10 <sup>1</sup>

<sup>1</sup> Medical office transit capture was estimated by BART

Source: BART (1)

**Exhibit 11-10. Commercial parking reductions granted at selected TODs.**

Location	Land Use	Parking Reduction
Pacific Court (Long Beach, CA)	Retail	60%
Uptown District (San Diego, CA)	Commercial	12%
Rio Vista West (San Diego, CA)	Retail/Commercial	15%
Pleasant Hill (CA)	Office	34%
Pleasant Hill (CA)	Retail	20%
Dadeland South (Miami, FL)	Office	38%
City of Arlington (VA)	Office	48%-57%
Lindbergh City Center (Atlanta, GA)	Speculative Office	19%
Lindbergh City Center (Atlanta, GA)	Retail	26%
Lindbergh City Center (Atlanta, GA)	Single Tenant Office Towers	29%-70%
Portland (OR) Suburbs <sup>a</sup>	General Office	17%
Portland (OR) Suburbs <sup>a</sup>	Retail/Commercial	18%

Note: <sup>a</sup> Calculated relative to maximums specified in Metro's Title 2 Regional Parking Ratios.

Source: *Statewide TOD Study (28)*

center, (2) high-density residential and commercial areas with good pedestrian access, (3) long-established outlying business districts, and (4) locations of strong cultural or historic interest, where the existing urban fabric should be enhanced. Examples include 125th Street in Manhattan; the Red Line through Cambridge, Massachusetts; and the Blue and Orange Lines through Arlington County, Virginia.

8. **Provide Developments With Appropriate Parking.** Most outlying rapid transit rail stations provide extensive park-and-ride space at suburban stations. The spaces are usually open-lot parking. When TOD is provided at or adjacent to these stations, careful review of parking demand is required. Travel modes to TOD office and retail typically rely less on driving than other suburban developments (25). More rather than less parking generally should be provided to accommodate the increased use. This is sometimes achieved by converting open-lot parking into structured parking. Sometimes a new parking garage is built for the planned developments. Cost-sharing policies are desirable. The Urban Land Institute, for example, suggests more parking, particularly a new parking structure connecting to the station boarding platform (26).

Some communities have granted commercial parking reductions at selected TODs. Reported examples are given in Exhibit 11-10. In 2005, about 70 percent of the transit agencies with replacement policies reported requiring one-for-one replacement (or more) of station parking lost to TOD construction (27).

Several transit agencies, including BART and WMATA, now allow park-and-ride space reductions upon introduction of TOD (29).

## Comparisons of TOD and Park-And-Ride

TOD can be a complement or an alternative to park-and-ride. The key considerations include the size, location, and density of TOD and the surrounding areas. Comparisons should include public cost and ridership impacts. Considerations include:

- Large office and mixed-use complexes located close to rapid transit stations can attract new riders, provided the service is direct and convenient. The CBDs of many large cities are prime

examples, as are some other outlying TODs (e.g., Lloyd District in Portland, Oregon; Mall of America in Bloomington, Minnesota, and Silver Spring, Maryland). High development densities, coupled with limited and expensive parking, are conducive to rapid transit ridership. This is also the case for some major outlying TODs.

- Typical TODs can sometimes create additional ridership when there is no change in transit parking space, or where the existing park-and-ride spaces are under-utilized.
- Where TOD reduces fully utilized park-and-ride space, the TOD ridership gain usually does not offset the ridership loss from transit parking reductions.
- Park-and-ride facilities require public investments to build and operate the parking space. Sometimes part (or all) of this investment can be recovered from parking charges. In contrast, TOD usually requires little, if any, public costs; it can also generate tax revenues for the neighboring community.

### Costs

Illustrative costs for park-and-ride facilities were derived from information published by the Institute of Transportation Engineers. They are expressed in both cost per space and costs per thousand feet of ground area. Exhibit 11-11 shows the key assumptions. Exhibit 11-12 shows the estimated costs for surface lots, above-grade parking structures, and below-grade parking structures. Both construction and operating costs are indicated.

The annual average debt service is based on a 4 percent interest rate and a 30-year service life. Longer debt service (amortization) periods would reduce these annual costs slightly.

### Riders

The number of rapid transit riders generated by park-and-ride facilities and TOD depend upon the amount of parking space and TOD provided, the trips generated per space or square foot of development, the likely number of passengers per vehicle, and the likely rapid transit capture rates. Ridership estimates also can be based on the experience at stations elsewhere along the line.

**Exhibit 11-11. Key assumptions for parking facility development (2010 dollars).**

<b>Construction Costs (2008-10)</b>	
Lot	\$4,200 – 5,250 per space
Garage	\$14,000 – 17,000 per space
Underground	\$25,000 – 35,000 per space
Capital Recover Factor	4% over 30 years = 0.05783
<b>Annual Operating Costs</b>	
Lot	\$100-130 per space
Garage	\$800 per space
Underground	\$1,000 per space
<b>Parking Space Size</b>	
Urban lot	300 square feet
Suburban lot	400 square feet
Garage	300 square feet

Source: *Transportation Planning Handbook (30)*

**Exhibit 11-12. Estimated annual parking costs per thousand square feet of ground area.**

Parking Type	Spaces/ 1,000 sq ft	Total capital costs	Annual capital costs <sup>a</sup>	Annual operating costs	Total annual Costs
Surface Lot					
Urban	3.3	\$11,550	\$668	\$330	\$998
Suburban	2.5	\$12,500	\$723	\$330	\$1,053
Above-Grade Structure					
2 levels	6.6	\$92,400	\$5,343	\$10,623	\$15,966
4 levels	14.2	\$198,000	\$11,450	\$22,010	\$33,460
6 levels	19.8	\$316,800	\$18,320	\$34,160	\$52,480
Underground					
1 level	3.3	\$82,500	\$4,771	\$8,021	\$12,792
2 levels	6.6	\$198,000	\$11,450	\$18,050	\$29,500
3 levels	9.7	\$346,500	\$20,038	\$29,938	\$49,976
Bus Bay	0.2	\$200,000	\$11,570	\$6,158	\$17,728
Bike Parking	20	\$4,000	\$231	\$731	\$962

Note: Excludes land costs

<sup>a</sup> 4% over 30 years

Source: *Transportation Planning Handbook (30)*

The comparative analysis is keyed to the trip generation and ridership per 1,000 square feet of effective ground floor area. The rapid transit boardings and alightings per 1,000 square feet of ground floor area for each type of land user can be estimated as follows:

$$R = X \times V \times N \times O \times P$$

where:

$R$  = rapid transit riders per day per 1,000 square feet of development;

$X$  = proportion of area available for development;

$V$  = vehicle trip ends per 1,000 square feet of ground floor space;

$O$  = people per automobile;

$P$  = rapid transit capture rate (% of TOD patrons using rapid transit); and

$N$  = number of floors or levels.

### *Trip Rates and Vehicle Occupancies*

Examples of automobile trip ends (origins plus destinations) for residential, retail, office, and park-and-ride uses are shown in Exhibit 11-13. The residential and commercial uses are based on Institute of Transportation Engineers' trip generation rates; the "effective" rates for these uses assume that part of the ground floor (or area) would be devoted to parking that would serve the TOD. These rates are a guide; agencies can modify them to reflect specific local conditions.

The table also shows suggested car occupancies ranging from 1.0 to 1.3 people per vehicle that may be assumed for various uses. In practice, occupancies will vary by time of day.



**Exhibit 11-13. Vehicle and passenger trip ends per day per thousand square feet of ground area.**

Use	Vehicle trip ends/day/1,000 square feet	Passenger trip ends/day/1,000 square feet for various car occupancies		
Vehicle Occupancy		1.1	1.2	1.3
Office	11	12.1	13.2	14.3
Retail	43	47.3	51.6	55.9
Residential	4 – 6	4.4 – 6.6	4.8 – 7.2	5.2 – 7.8
Park-and-Ride	5 – 6.6	5.5 – 7.3	6 – 7.9	6.5 – 8.6

**Source:** ITE trip generation data for office, retail, residential.  
Park-and-Ride: 2.5-to-3.5 spaces/1,000 square feet times 2 trips per space

### *Proportion Riding Rapid Transit*

Park-and-ride trips are oriented to the rapid transit line. Trips to and from retail, residential, and office uses would likely come from several directions, hence the proportion would be less (typically 10 to 20 percent). However, very large office complexes could likely attract 25 percent or more of generated trips from transit. Some people live close to the rapid transit line to reach large city centers. In these cases, higher transit mode splits are likely. Therefore, transit agencies should base percentages on actual experience.

### *Illustrative Effects*

Illustrative rapid transit ridership effects of TOD and park-and-ride at outlying stations are shown in Exhibit 11-14. The values give the estimated number of transit riders per 1,000 square feet of ground area. Estimates are provided for park-and-ride (lot or garage), and residential, office, and retail developments.

Exhibit 11-14 shows that 1,000 square foot of development could generate approximately five to seven daily riders if dedicated to park-and-ride, while 1,000 square feet of retail would generate slightly higher transit ridership. Per square foot, residential and office development are likely to generate significantly fewer riders than would an equivalent amount of park-and-ride. High-rise residential or office development could generate more ridership than park-and-ride space, if sufficient demand existed to justify high-rise development.

There are of course many important reasons for providing TOD, other than ridership. TOD can improve the character of an area, make it more cohesive, and possibly attract economic

**Exhibit 11-14. Estimated weekday transit ridership for various land uses.**

Land Use	Daily passenger trip ends per thousand square feet <sup>a</sup>	Estimated proportion by line-haul transit	Daily transit riders
Office	12 – 14	0.20	2.4 – 2.8
Retail	47 – 56	0.15	7 – 8.4
Residential	4.4 – 7.2	0.20	0.9 – 1.4
Park-and-Ride	5.5 – 7.3	1.0	5.5 – 7.3

<sup>a</sup> Assumes vehicle occupancy of 1.2 persons per vehicle.

development to an area. But it, too, will require some parking, and it generally should not be viewed as a replacement of needed parking space.

As described here, transit agencies must decide how to use the land around their stations. The trade-offs between parking and development are complicated and largely depend on external factors, such as parking demand and the development market. Still, transit agencies can evaluate opportunities in terms of costs and ridership. Exhibit 11-15 illustrates the ridership potential of parking and development opportunities for a hypothetical one-acre site.

**Exhibit 11-15. Example development options for 1-acre site adjacent to transit station.**

	Development type <sup>a</sup>	Size	Cost per rider (2010 dollars) <sup>b</sup>	Potential daily ridership
Parking <sup>c</sup>	Surface lot	144 spaces	\$191.01	164 riders
	2-level garage	287 spaces	\$1,038.57	328 riders
	4-level garage	575 spaces	\$1,294.18	655 riders
	2-level underground garage	287 spaces	\$1,805.41	328 riders
Residential <sup>d</sup>	0.5 FAR <sup>g</sup>	22 housing units	\$ -	22 riders
	1.0 FAR	44 housing units	\$ -	52 riders
	2.0 FAR	87 housing units	\$ -	105 riders
	3.0 FAR	131 housing units	\$ -	196 riders
	4.0 FAR	174 housing units	\$ -	261 riders
	5.0 FAR	218 housing units	\$ -	327 riders
Office <sup>e</sup>	0.5 FAR	65 employees	\$ -	20 riders
	1.0 FAR	131 employees	\$ -	39 riders
	2.0 FAR	261 employees	\$ -	78 riders
	3.0 FAR	392 employees	\$ -	118 riders
	4.0 FAR	523 employees	\$ -	157 riders
	5.0 FAR	653 employees	\$ -	196 riders
Retail <sup>f</sup>	0.5 FAR	21.8 ksf	\$ -	109 riders
	1.0 FAR	43.6 ksf	\$ -	218 riders
	2.0 FAR	87.1 ksf	\$ -	436 riders

Notes: <sup>a</sup> Assumes sufficient market demand for all parking and development types.

<sup>b</sup> Parking costs assume \$3,500 per space for a surface lot, \$20,000 per space for a garage, and \$35,000 per space for underground.

<sup>c</sup> Parking calculations assume 350 square feet per parking stall, 1 vehicle parked per day, with 1.2 vehicle occupancy, and 2 boardings per rider.

<sup>d</sup> Residential calculations assume 1,000 square feet per unit, 10 trips per day per unit, and a 10-15% transit capture (increasing with density).

<sup>e</sup> Office calculations assume 3 workers per 1,000 square feet, 2 trips per day per worker, and a 15% transit capture.

<sup>f</sup> Retail calculations assume 50 daily trips per 1,000 square feet and a 10% transit capture.

<sup>g</sup> FAR = Floor Area Ratio

Source: Kittelson & Associates, Inc. and Peter Martin

Assuming a one-acre site adjacent to a high-capacity transit station, how might a transit agency plan for station access? In general, parking structures provide a high-ridership potential, assuming sufficient parking demand exists. A four-level parking garage can yield 650 daily transit riders. On the other hand, a 10-story residential development (assumed Floor Area Ratio of 5.0) on the same site might provide 350 daily riders. From a transit agency perspective, the four-story parking garage would cost over \$14 million dollars (or nearly \$1,300 per rider), whereas the development poses no significant cost to the agency if it can be funded through private sources. In fact, if the agency owns the land in the station area, it can potentially appreciate income related to the ground rent.

The spreadsheet tool provided as Appendix C allows users to test similar hypothetical scenarios with additional options for refinement.

## Implications and Directions

The following implications relating to development adjacent to rapid transit stations emerge from the preceding discussion:

1. Land development has followed many rapid transit lines over the years. It should be encouraged along existing and proposed lines—especially around stations. One possibility is to establish rapid transit corridor overlay zones.
2. Efforts should focus on the city center and other major activity concentrations. It is important to guide land development in undeveloped areas in advance of rapid transit operation. Stations with strong back-up residential populations are also good candidates for TOD.
3. The types and sizes of TOD should recognize the market opportunities (and constraints) of specific station areas. Developments around stations range from ancillary convenience activities to the CBD.
4. Land developments around stations can provide important benefits in terms of community integration and design. They should provide good access between nearby residential and commercial development and stations.
5. TOD is an important complement to rapid transit stations. Developing TOD can improve the community tax base, facilitate walkability, and offer convenience to both transit patrons and motorists.
6. The types of TOD will depend upon location, land availability and costs, and market potentials. These types include: (1) convenience activities that are located within the station complex; (2) adjacent commercial, office, or residential developments, or a combination; (3) adjacent or nearby major activity centers; and (4) housing.
7. In many cases, both TOD and park-and-ride can be provided in the station environs. For example, many rapid transit stations are located at cross streets. This results in four quadrants around the station. TOD can be provided in some quadrants; park-and-ride in others.
8. The emphasis on TOD versus park-and-ride depends on: (1) where the station is or will be located; (2) the character of the surrounding areas; and (3) the market potentials of planned developments. Where stations are located in built-up areas and where policy favors TOD, auto access should be limited to passenger drop-off and pick-up.
9. Where buses and pedestrians are the main means of station access, TOD is usually more desirable than large park-and-ride facilities. Location, type of development, and market potentials are important.
10. The rapid transit ridership effects of TOD vary. They are significant in the city center, and other activity concentrations. However, not all TODs have significant ridership impacts. Connectivity, rapid transit service efficiency, availability of free parking for drivers, and the development market all figure into its success.

**Exhibit 11-16. Direct connection from station to development (Ottawa, Ontario).**



**Source:** Kittelson & Associates, Inc.

11. There are many situations where the station environs can provide both TOD and the necessary transit parking space. In these cases more, rather than less, parking will be required. This situation could also result in increased rapid transit ridership.
12. Pedestrian-friendly designs should minimize walking distances to stations from adjacent TODs (see Exhibit 11-16).

In sum, TOD should be viewed as a complement to station parking to the maximum extent possible. The eight-step planning process described in Chapter 2 provides a framework for establishing an appropriate balance between TOD and park-and-ride needs.

---

---

## References

1. Willson, Richard and Menotti, Val. Commuter Parking Versus Transit-Oriented Development: Evaluation Methodology. In *Transportation Research Record: Journal of the Transportation Research Board, No. 2021*, Transportation Research Board of the National Academies, Washington, DC, 2007, pp. 118–125.
2. Ragovin, I. “Getting Around Gets Easier.” Planning American Planning Associations, Feb. 2011.
3. Kathryn F. Turnbull, Richard H. Pratt, John E. Evans, IV, and Herbert S. Levinson. *TCRP Report 95: Traveler Response to Transportation System Changes, Chapter 3—Park-and-Ride/Pool*. Transportation Research Board of the National Academies, Washington, DC, 2004.
4. Parsons Brinckerhoff Quade & Douglas, Inc., Cambridge Systematics Inc., and NuStats International. “RT-HIS Regional Travel—Household Interview Survey.” Executive Summary General, Final Report. Prepared for the New York Metropolitan Transportation Council and the North Jersey Transportation Planning Authority, February, 2000.
5. Ferguson, E. “Parking Management and Commuter Rail: The Case of Northeastern Illinois.” *Journal of Public Transportation*, Vol. 3, No. 2, 2000.
6. McCollom Management Consulting, Inc. “Transit Performance Monitoring System: First Phase Testing” (draft report). Prepared for the American Public Transit Association. APTA, Washington, DC, March, 1999.
7. Caltrain. *2001 Caltrain Origin and Destination Study*. Peninsula Corridor Joint Powers Board, San Carlos, CA, August 20, 2003.
8. BART Customer and Performance Research. *BART Station Profile Study*. Final Report. Oakland, CA, August, 1999.
9. Houston-Galveston Area Council. “Regional Travel Models—1995 Model Validation and Documentation Report.” Supplemental tabulations prepared by Parsons Brinckerhoff: “HGAC Model Development, Mode Choice Calibration Targets, Mode Availability by Purpose and Time Period.” Houston, TX, February, 2001.
10. United States Census 2000 Demographic Profiles.
11. Wilson, A. P. *CTPS Technical Report 47: An Impact Analysis of the Opening of the Quincy Adams Rapid-Transit System*. Central Transportation Planning Staff, Boston, MA, 1984.
12. Cervero, R. *Ridership Impacts of Transit-Focused Development in California*. Monograph 45. Institute of Urban and Regional Development, University of California at Berkeley, 1993.
13. Loutzenheiser, O. “Redistributing Access to Transit: A Model of Walk Trips and their Design and Urban Form Determinates Around BART Stations.” Presented at 74th Annual Meeting of the Transportation Research Board, Washington, DC, 1997.
14. Evans, John E., Richard H. Pratt, Andrew Stryker, and J. Richard Kuzmayak. *TCRP Report 95: Traveler Response to Transportation System Changes, Chapter 17—Transit Oriented Development*. Transportation Research Board of the National Academies, Washington, DC, 2004.
15. Washington Metropolitan Area Transit Authority (WMATA). *Metrorail Passenger Surveys: Average Weekday Passenger Boardings*. Spreadsheets, June 6, 2002 and June 14, 2006b.
16. Levinson, H. S., and Weant, R. A. *Transportation and Parking Demand Analysis for Bridgeport Intermodal Transportation Center*. Prepared for Wallace Floyd Design Group, Boston, MA, August 30, 2000.
17. Kittelson Assoc. Inc., Herbert S. Levinson, and DMJM + Harris. Chapter 3 in *TCRP Report 118: Bus Rapid Transit Practitioners Guide*, Transportation Research Board of the National Academies, Washington, DC, 2009.
18. KFH Group, Inc. *TCRP Report 99: Embracing Change in a Changing World*. Transportation Research Board of the National Academies, Washington, DC, 2004.
19. Krambles, G., and Peterson, A.A. *CTA at 45*. George Krambles Scholarship Foundation, 1993.
20. Levinson, Herbert, Samuel Zimmerman, Jennifer Clinger, Scott Rutherford, Rodney L. Smith, John Cracknell, and Richard Soberman. *TCRP Report 90: Bus Rapid Transit Volume I: Case Studies in Bus Rapid Transit*. Transportation Research Board of the National Academies, Washington, DC, 2003.

21. Arrington, G.B. and R. Cervero. *TCRP Report 128: Effects of TOD on Housing, Parking, and Travel*. Transportation Research Board of the National Academies, Washington, DC, 2008.
22. Cervero, Robert, Steven Murphy, Christopher Ferrell, Natasha Goguts, Yu-Hsin Tsai, G.B. Arrington, John Boroski, Janet Smith-Heimer, Ron Golem, Paul Peninger, Eric Nakajima, Ener Chui, Robert Dunphy, Mel Myers, Shannon McKay, and Nicole Witenstein. *TCRP Report 102: Transit-Oriented Development in the United States: Experiences, Challenges, and Prospects*. Transportation Research Board of the National Academies, Washington, DC, 2004.
23. DRAFT—FasTracks TOD Lessons Learned Report, March, 2010.
24. Trimet. *Community Building Source Book—Land Use and Transportation Initiatives in Portland*, 2005.
25. Cervero, Robert and G.B. Arrington. Vehicle Trip Reduction Impacts of Transit-Oriented Housing. *Journal of Public Transportation*, Vol. 11, No. 3, 2008.
26. The Ground Floor, Parking and Neighborhoods Should Be The Focus of TOD. April 5, 2000
27. Evans, J.E., IV, and Stryker A. TCRP Project B-12B Technical Report 1, Prepared for Richard H. Pratt, March 2005.
28. Borowski, J., T Faulkner, G. Arrington, S. Mori, F. Parker, and D. Mayer. *Statewide Transit-Oriented Development Study—Factors for Success in California: Special Report: Parking and TOD*. Prepared for California Department of Transportation by Parsons Brinckerhoff and Faulkner/Conrad Group, February 2002.
29. Millard-Ball A., and Siegman P. Playing the Numbers Game. *Planning Magazine*, American Planning Association, May, 2006.
30. *Transportation Planning Handbook*, 3rd Edition. Institute of Transportation Engineers. Washington, DC, 2008.
31. Cottrell, Wayne D. Transforming a Bus Station into a Transit-Oriented Development: Improving Pedestrian, Bicycle, and Transit Connections. In *Transportation Research Record, Journal of the Transportation Research Board*, No. 2006. Transportation Research Board of the National Academies, Washington, DC, 2007, pp. 114–121.
32. Coffel, Kathryn, Jamie Parks, Conor Semler, David Sampson, Chris Henry, Guillermo Calves, Carol Kachadoorian, Herbert Levinson, and Joseph Schofer. *TCRP Web-Only Document 44: Literature Review for Providing Access to Public Transit Stations*. Transportation Research Board of the National Academies, Washington, DC, 2009.
33. Schlossberg, Marc, Asha Weinstein Agrawal, Katja Irvin, and Vanessa Louise Bekkouch. *How Far, by Which Route, and Why? A Spatial Analysis of Pedestrian Preference*. Mineta Transportation Institute, San Jose, CA, 2007.
34. Bay Area Rapid Transit. *BART Station Access Guidelines*, San Francisco, CA, 2003.
35. Pucher, John, Ralph Buehler, and Mark Seinen. Bicycling Renaissance in North America? An Update and Re-Appraisal of Cycling Trends and Policies, *Transportation Research*, Part A, Vol. 45, 2011 (in press).
36. Debrezion, Ghebreegziabiher, Eric A.J.H. Pels, and Pie Rietveld. *Modelling the Joint Access Mode and Railway Station Choice*. Tinbergen Institute, Discussion Paper No. 07-012/3, January 2007.
37. Park, Sungjin and Junhee Kang. Factors that Influence Walking and Biking to the Station: Modeling Commuter Rail Users' Access Mode Choice. Presented at 88th Annual Meeting of the Transportation Research Board, Washington, DC, January, 2008.
38. Nankervis, Max. The Effect of Weather and Climate on Bicycle Commuting, *Transportation Research Part A*, pp. 417–431, 1999.
39. Alta Planning + Design, Inc. *Bicycle Transportation Strategic Plan*. Los Angeles Metropolitan Transportation Authority, 2006.
40. Kittelson & Associates, Inc., KFH Group, Inc., Parsons Brinckerhoff Quade & Douglas, Inc., and Dr. Katherine Hunter-Zaworski. *TCRP Report 100: Transit Capacity and Quality of Service Manual*, 2nd Edition. Transportation Research Board of the National Academies, Washington, DC, 2003.
41. Levinson, H.S., C.L. Adams, and W.F. Hoey. *NCHRP Report 155: Bus Use of Highways: Planning and Design Guidelines*. TRB, National Research Council, Washington, DC, 1975.
42. Weant R.A. and H.S. Levinson. *Parking*. ENO Transportation Foundation, Westport, CT, 1990.
43. Levinson, H.S., J.S. Gluck, and W. Ng. Park-and-Ride, Kiss-and-Ride, and Change of Mode Facilities. In *Parking Management—Planning, Design, and Operations*, International Parking Institute Inc., Fredericksburg, VA, 2009.
44. Bowler Charles, E., Errol C. Noel, Richard Peterson, and Dennis Christiansen. *Park-and-Ride Facilities-Guidelines for Planning, Design, and Operation*. Federal Highway Administration, U.S. Department of Transportation, Washington, DC, 1986.
45. City of Calgary. *1998 Park-and-Ride Lot Inventory*. Calgary, Alberta, Canada, 1998.
46. *Report on New Haven Line Parking Expansion*. Connecticut Department of Transportation, Hartford, CT, 1997.
47. *Parking at DART Transit Centers, Park and Ride Lots, Rail Station*. Dallas Area Rapid Transit, Dallas, TX, 1998.

48. Dickins, I. Light Rapid Transit and Strategic Park and Ride: A Modern System. *Proceedings of Light Rail '93 Conference*, Birmingham, England, 1994.
49. Foote, P. J. Chicago Transit Authority Weekday Park-and-Ride Users: Choice Market with Ridership Growth Potential. In *Transportation Research Record, Journal of the Transportation Research Board, No. 1735*, TRB, National Research Council, Washington, DC, 2000, pp. 158–168.
50. *Parking Management-Utilization Statistics-February 1998*. Go Transit, Toronto, Ontario, Canada, 1998.
51. *1993 Park-Ride Facilities*. Metro-Dade Transit Authority, Miami, FL, 1993.
52. Metropolitan Transit Development Board. Metropolitan Transit Development Board, San Diego, CA, 1999.
53. *Washington Regional Park-and-Ride 1995 Inventory and Analysis*. Metropolitan Washington Council of Governments, Washington, DC, 1996.
54. “1994 . . .,” “1995 . . .,” “1996 . . .,” “1997 . . .,” and “1998 Park-and-Ride Utilization Summary.” Tabulations, Regional Transit District, Denver, CO, 1999.
55. 2009 Park and Ride Survey. Santa Clara Valley Transportation Authority, San Jose, CA, 2009.
56. *Parking Pricing Study*. Sound Transit, Seattle, WA, 2010.
57. Turnbull, K. F., P. A. Turner, and N. F. Lindquist. *Investigation of Land Use, Development, and Parking Policies to Support the Use of High-Occupancy Vehicles in Texas*. Texas Transportation Institute, College Station, TX, 1995.
58. City of Ottawa Transportation and Infrastructure Planning: Park-And-Ride Facilities for Ottawa Part 1: Best Practices and Policy Directions. ITrans Consulting, Inc., Ottawa, Canada, November 2007.
59. This Week’s Survey Results—Characteristics of Successful Park-and-Ride Lots. *Urban Transportation Monitor*, Vol. 17, No. 11, June 13, 2003b.
60. RTD Transit Access Guidelines—Regional Transit District, Denver, CO, January 2004.



# List of Agency Abbreviations

<b>Abbreviation</b>	<b>Agency</b>	<b>Location</b>
BART	Bay Area Rapid Transit	San Francisco, CA
Capital Metro	Capital Metropolitan Transportation Authority	Austin, TX
CATS	Charlotte Area Transit System	Charlotte, NC
CTA	Chicago Transit Authority	Chicago, IL
El	Chicago “L”	Chicago, IL
LTD	Lane Transit District	Eugene, OR
MARC	Maryland Area Rail Commuter Train	Baltimore-Washington Metro
MARTA	Metropolitan Atlanta Rapid Transit Authority	Atlanta, GA
MBTA	Massachusetts Bay Transportation Authority	Boston, MA
Metro North	Metro-North Commuter Railroad	New York Metro (NY, CT)
MTA	Los Angeles County Metropolitan Transportation Authority	Los Angeles, CA
MTA	Maryland Transit Administration	Maryland
MTA	Metropolitan Transportation Authority	New York, NY
NJ Transit	New Jersey Transit	Newark, NJ
NYCT	New York City Transit	New York, NY
Pace	Pace Suburban Bus Division of RTA	Chicago, IL
PAT	Port Authority of Allegheny County	Pittsburgh, PA
PATH	Port Authority of New York & New Jersey	New York-New Jersey
RTD	Regional Transportation District	Denver, CO
SFRTA	South Florida Regional Transportation Authority	Miami, FL (metro area)
TriMet	Tri-County Metropolitan Transportation District	Portland, OR
VTA	Valley Transit Authority	San Jose, CA
WMATA	Washington Metropolitan Area Transit Authority	Washington, DC





## Appendices A Through E

Appendices A through E are not published herein, but are available on the TRB website at <http://www.trb.org/Main/Blurbs/166516.aspx>. The titles are:

Appendix A: Summary of Stakeholder Survey and Literature Review

Appendix B: Overview of Existing Analysis and Evaluation Tools

Appendix C: Spreadsheet-Based Access Tool and Instructions (Electronic)

Appendix D: Detailed Station-Level Access Data

Appendix E: Detailed Station Access Case Studies

*Abbreviations and acronyms used without definitions in TRB publications:*

AAAE	American Association of Airport Executives
AASHO	American Association of State Highway Officials
AASHTO	American Association of State Highway and Transportation Officials
ACI-NA	Airports Council International-North America
ACRP	Airport Cooperative Research Program
ADA	Americans with Disabilities Act
APTA	American Public Transportation Association
ASCE	American Society of Civil Engineers
ASME	American Society of Mechanical Engineers
ASTM	American Society for Testing and Materials
ATA	Air Transport Association
ATA	American Trucking Associations
CTAA	Community Transportation Association of America
CTBSSP	Commercial Truck and Bus Safety Synthesis Program
DHS	Department of Homeland Security
DOE	Department of Energy
EPA	Environmental Protection Agency
FAA	Federal Aviation Administration
FHWA	Federal Highway Administration
FMCSA	Federal Motor Carrier Safety Administration
FRA	Federal Railroad Administration
FTA	Federal Transit Administration
HMCRP	Hazardous Materials Cooperative Research Program
IEEE	Institute of Electrical and Electronics Engineers
ISTEA	Intermodal Surface Transportation Efficiency Act of 1991
ITE	Institute of Transportation Engineers
NASA	National Aeronautics and Space Administration
NASAO	National Association of State Aviation Officials
NCFRP	National Cooperative Freight Research Program
NCHRP	National Cooperative Highway Research Program
NHTSA	National Highway Traffic Safety Administration
NTSB	National Transportation Safety Board
PHMSA	Pipeline and Hazardous Materials Safety Administration
RITA	Research and Innovative Technology Administration
SAE	Society of Automotive Engineers
SAFETEA-LU	Safe, Accountable, Flexible, Efficient Transportation Equity Act: A Legacy for Users (2005)
TCRP	Transit Cooperative Research Program
TEA-21	Transportation Equity Act for the 21st Century (1998)
TRB	Transportation Research Board
TSA	Transportation Security Administration
U.S.DOT	United States Department of Transportation